

# Ultra-Force™

Commercial Gas Water Heaters  
With 94% Thermal Efficiency and  
Electronic Control System



## MODELS COVERED

SUF100 150NE

SUF100 199NE

SUF100 240NE

Also includes Parts List

# SUF Service Handbook

## TABLE OF CONTENTS

<b>Introduction</b> . . . . .	2	<b>Troubleshooting (continued)</b>	
<b>Installation</b>		Blower . . . . .	25
Clearances . . . . .	3	Pressure Switch Performance . . . . .	26 – 27
Gas Requirements . . . . .	3	120 VAC to Ignitor . . . . .	28
Venting . . . . .	4 – 8	Ignitor Resistance. . . . .	29
Air Requirements . . . . .	9 – 11	Gas Valve Test . . . . .	30
Contaminated Air . . . . .	12	Gas Pressure Check . . . . .	31
Flammable Items . . . . .	12	<b>Component Information</b>	
Multiple Unit Piping. . . . .	13	Orifice Tables . . . . .	32
Condensation . . . . .	14	Pressure Switches . . . . .	33 – 34
<b>Operation</b>		<b>Wiring Diagrams</b> . . . . .	35
Sequence of Operation . . . . .	15	<b>Service Aids</b> . . . . .	36
Controls . . . . .	16	SUF Muffler . . . . .	37
Circuit Boards. . . . .	17	<b>Questions &amp; Answers</b> . . . . .	38
<b>Troubleshooting</b>		<b>Error Codes.</b> . . . . .	39
Pre-Service. . . . .	18	<b>Service Checklist</b> . . . . .	40
120 VAC to Control. . . . .	18	<b>Parts Lists</b>	
Transformer . . . . .	19 – 20	Models 100 – 150, 100 – 199, and 100 – 240 . . . . .	41 – 43
ECO Check . . . . .	21 – 22		
Temperature Probe. . . . .	23		
Pressure Switch Continuity . . . . .	24		

---

## INTRODUCTION

This service handbook is designed to aid in servicing and troubleshooting State SUF 150, 199 and 240 water heaters. No duplication or reproduction of this book may be made without the express written authorization of the State Water Heaters Company.

The following text and illustrations will provide you with a step by step procedure to verify proper installation, operation and troubleshooting procedures. Additional quick reference data is included to assist you in servicing this product.

The information contained in this handbook is designed to answer commonly faced situations encountered in the operation of the SUF product line and is not meant to be all inclusive. If you are experiencing a problem not covered in this handbook, please contact the State Technical Information Department at 1-800-365-0577 or your local State Representative for further assistance. This handbook is intended for use by licensed plumbing professionals and reference should be made to the instruction manual accompanying the product. This handbook contains supplemental information to the SUF instruction manual.

**Qualifications:** Installation or service of this water heater requires ability equivalent to that of a licensed tradesman in the field involved. Plumbing, venting, gas supply and electrical testing skills are required.

**Tools Required:**

- Phillips head and flat tip screw drivers
- Set of marked drill bits
- Electric multimeter tester
- Gas pressure gauge or manometer (gauge — part number 8099-2)
- Water pressure gauge (part number 4798)
- Digital manometer or draft gauge
- Thermometer (part number 4870 — range 0 thru 220°F)
- 1/2", 1" and 1 1/8" sockets
- Pipe wrench for union disconnect

**NOTE** Also, have a copy of the instruction manual for the model and series SUF that you are servicing.

# INSTALLATION

## CLEARANCES

This portion of the handbook will review often overlooked installation requirements. The installation manual covers these items in detail. SUF water heaters are approved for installation on combustible flooring. The minimum clearance to combustibles or non-combustibles is 0 inches from the sides and rear, 0 inches from vent piping, and 1.5 inches from the top cover. A 24 inch clearance for all serviceable parts is recommended. Clearances may vary between SUF models. See installation manual or the label on the heater for your specific model.

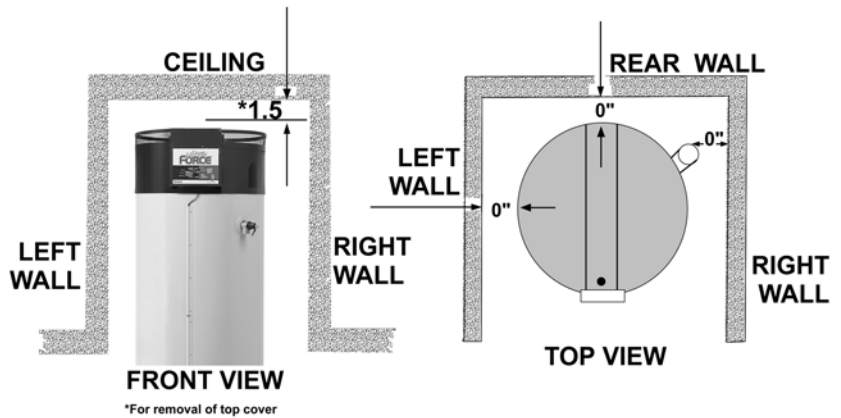

## GAS REQUIREMENTS

**NOTE :** Pressure without capacity will result in lockout. Follow the piping guidelines in the installation manual. The supply gas pressure is normally measured at the dirt leg or at the inlet gas pressure tap on the gas valve. This reading must be measured with 'flowing' gas.

The manifold gas pressure is measured at the manifold pressure tap on the gas valve when the gas is flowing. The gas valves used on all SUF water heaters are 24 VAC combination step opening gas valves. They incorporate the main valve and pressure regulator into one body.

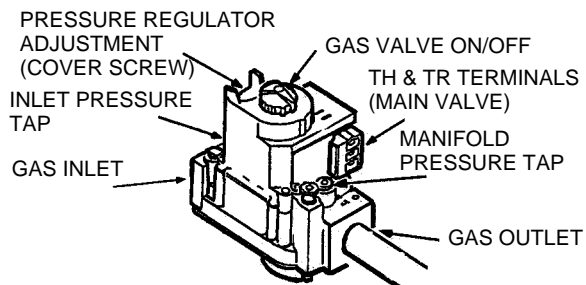
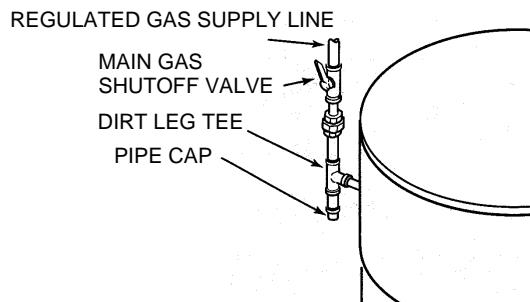

GAS SUPPLY SPECIFICATIONS	SUF 240	SUF 150 & 199	SUF 150 & 199
	NATURAL GAS	NATURAL GAS	PROPANE GAS
Max. Gas Supply Pressure Inches W.C.	12.0 (3 kPa)	12.0 (3 kPa)	14.0 (3.45 kPa)
Nominal Gas Supply Pressure Inches W.C.	7.0 (1.75 kPa)	7.0 (1.75 kPa)	11.0 (2.74 kPa)
Minimal Gas Supply Pressure Inches W.C.	5.5 (1.37 kPa)	4.5 (1.12 kPa)	11.0 (2.74 kPa)
Manifold Pressure Inches W.C.	4.0 (1 kPa)	3.5 (0.8 kPa)	10.0 (2.5 kPa)

## VENTING

### Equivalent Feet of Pipe Intake or Exhaust

VENT LENGTH TABLE			
NUMBER OF 90° ELBOWS	3" MINIMUM PIPE (FEET)	3" MAXIMUM PIPE (FEET)	4" MAXIMUM PIPE (FEET)
ONE (1)	7	45	115
TWO (2)	7	40	110
THREE (3)	7	35	105
FOUR (4)	7	30	100
FIVE (5)	7	--	95
SIX (6)	7	--	90

4-inch PVC may be used for a MAXIMUM intake of ONE HUNDRED TWENTY (120) EQUIVALENT FEET and a MAXIMUM exhaust of ONE HUNDRED TWENTY (120) EQUIVALENT FEET. The maximum number of 90° elbows with the 4-inch venting is six (6) on the intake and six (6) on the exhaust. A 90° elbow is equal to five (5) equivalent feet of pipe. One (1) 90° elbow is equal to two (2) 45° elbows. Any venting configuration using less than 50 equivalent feet should use 3-inch venting. See Vent Length Table.

The 3-inch venting terminals (provided) must be used with the 4-inch venting by adding 4 x 3 reducing coupling at the venting terminals. A reducing coupling is also needed immediately after the condensate elbow (exhaust) and immediately before the 3-inch blower adapter (intake) if direct venting is installed. See Vent Length Table.

### DIRECT VENTING

The air intake provided on the unit contains a mesh screen (see Figure below) to prevent large particles from entering the unit.

3" (7.6CM) 45° PVC ELBOW WITH MESH SCREEN

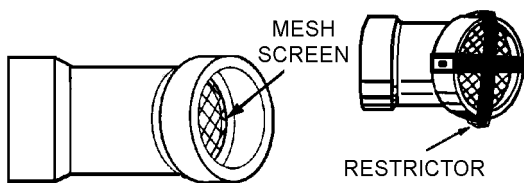

**WARNING** WHEN THE UNIT IS TO BE SETUP AS A DIRECT VENT, THE MESH SCREEN MUST BE REMOVED. THE INLET VENT PIPE MAY THEN BE GLUED TO THE AIR INTAKE (see following Figure) PROVIDED ON THE UNIT.

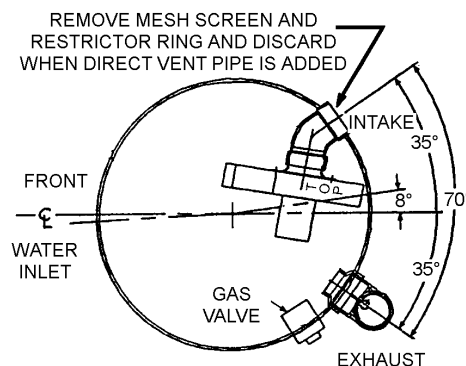

## VENTING CONFIGURATIONS

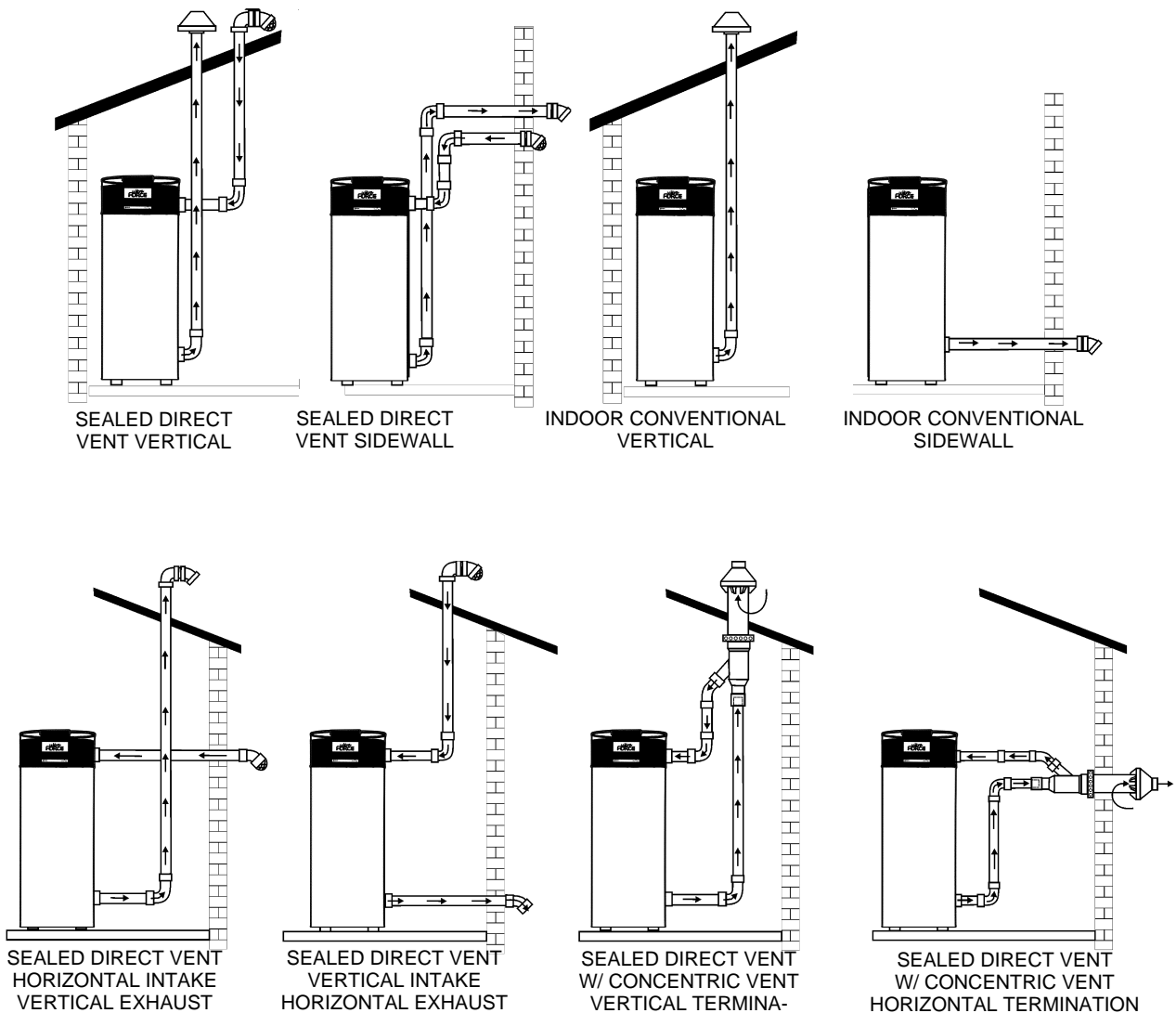

## VENTING MATERIALS

This unit can be vented using only PVC (Class 160, ASTM D-2241; Schedule 40, ASTM D-1785; or Cellular Core Schedule 40 DWV, ASTM F-891), Schedule 40 CPVC (ASTM F-411), or ABS (ASTM D-2661) pipe. The fittings, other than the TERMINATIONS should be equivalent to PVC-DWV fittings meeting ASTM D-2665 (Use CPVC fittings, ASTM F-438 for CPVC pipe and ABS fittings, ASTM D-2661/3311 for ABS pipe. If CPVC or ABS pipe and fittings are used, then the proper cement must be used for all joints, including joining the pipe to the Termination Tee (PVC Material). PVC Materials should use ASTM D-2564 Grade Cement; CPVC Material should use ASTM F-493 Grade Cement and; ABS Materials should use ASTM D-2235 Grade Cement.

For water heaters in locations with high ambient temperatures (above 100°F) and/or insufficient dilution air, it is recommended that CPVC or ABS pipe and fittings (MUST USE SUPPLIED VENT TERMINAL) be used.

### CONCENTRIC VENT TERMINATION

The concentric vent termination kit, Part No. 9003910005 can be used on SUF 150 – 240 Ultra Force water heaters. It adds zero equivalent feet to the vent system. Below are some general application and installation guidelines for the concentric vent kit. Refer to the accompanying literature and the water heater installation manual for complete venting installation instructions.

This concentric vent termination kit may be used with 3 or 4 in. diameter pipe systems. When connecting to a 4 in. diameter pipe system a 3 x 4 in. field supplied reducer is to be installed at the intake and exhaust connection of the concentric vent termination kit. See water heater installation and operation manual for venting specification

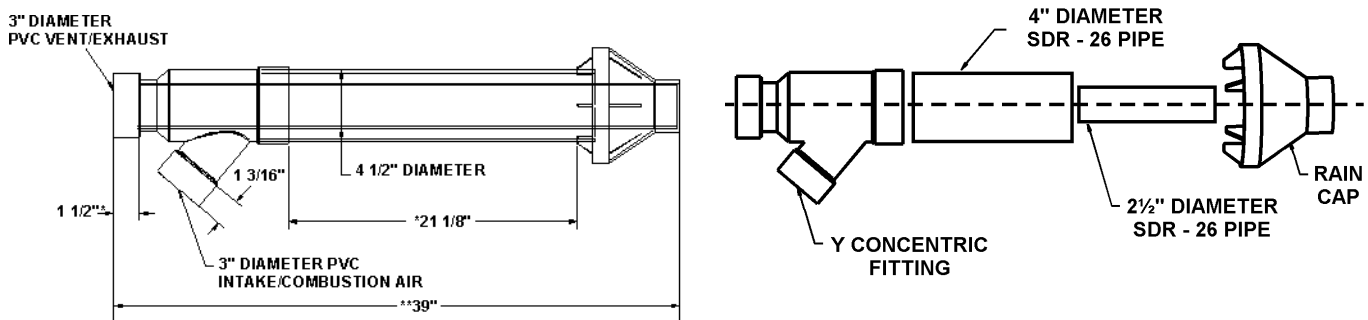

Dimension 21<sup>1</sup>/<sub>8</sub> in. may be lengthened to 60 in. maximum. Dimension 21<sup>1</sup>/<sub>8</sub> in. may also be shortened by cutting the pipes, provided in the kit, to 12 in. minimum. Dimension 39 will change accordingly as dimension 21<sup>1</sup>/<sub>8</sub> in. is lengthened or shortened

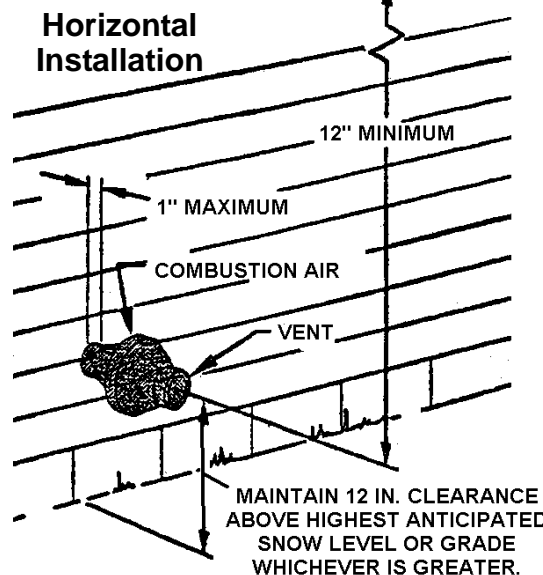
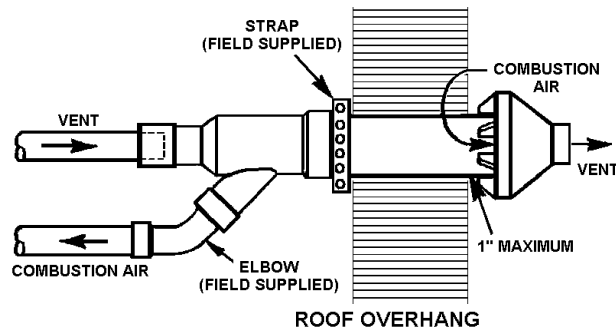
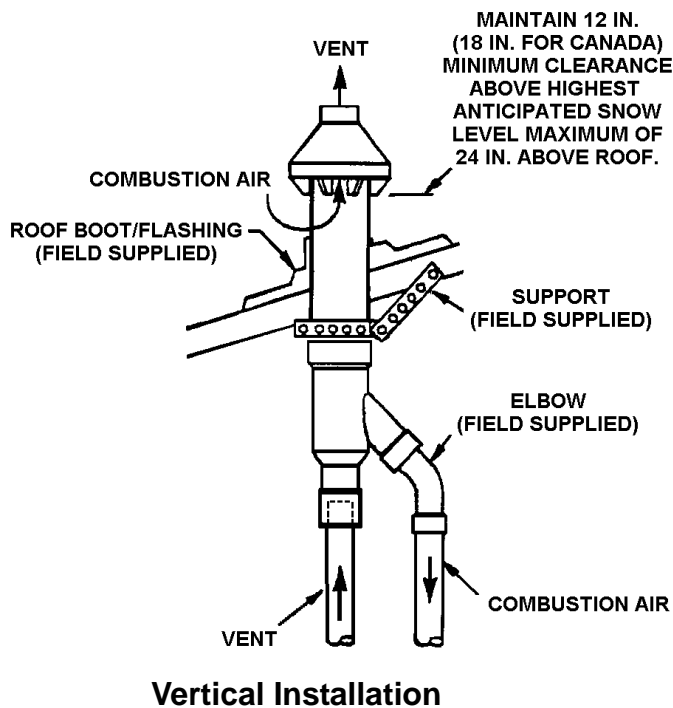

### VENTING CLEARANCES

This illustrates the exterior clearances for these SUF units when installed as direct vent heaters.

**NOTE :** 24 inches between inlet and outlet is a MINIMUM. Greater distance is recommended. In colder climates increasing the 24" minimum to a maximum practical distance will reduce the possibility of frost over from side winds blowing exhaust vapors into the air intake.

SUF MODEL 150 – 199

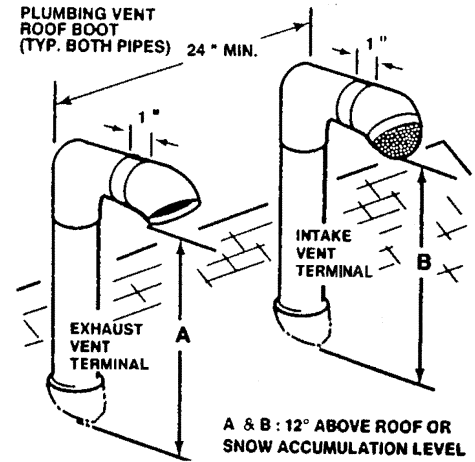
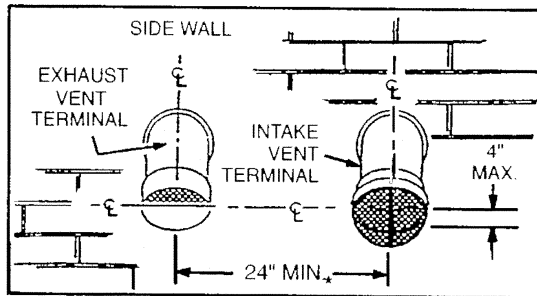

SUF MODEL 240

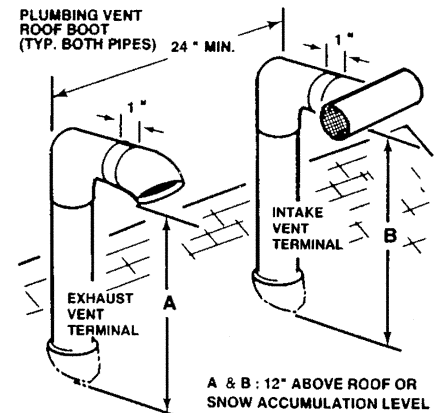
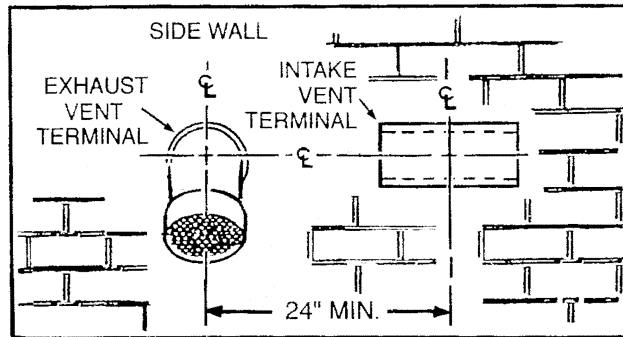



## EXTERIOR SIDEWALL CLEARANCES

### Horizontal Vent (Using Room Air for Combustion)

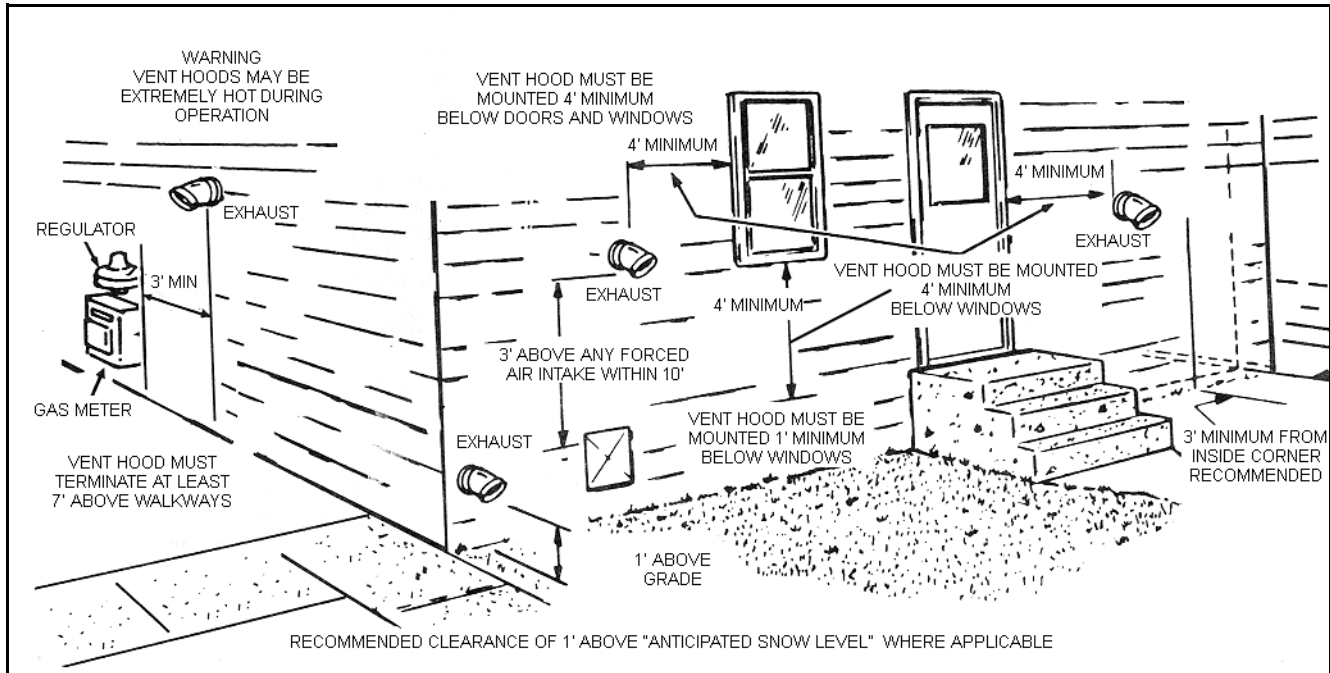

### Horizontal Direct Vent (Using Outdoor Air for Combustion)

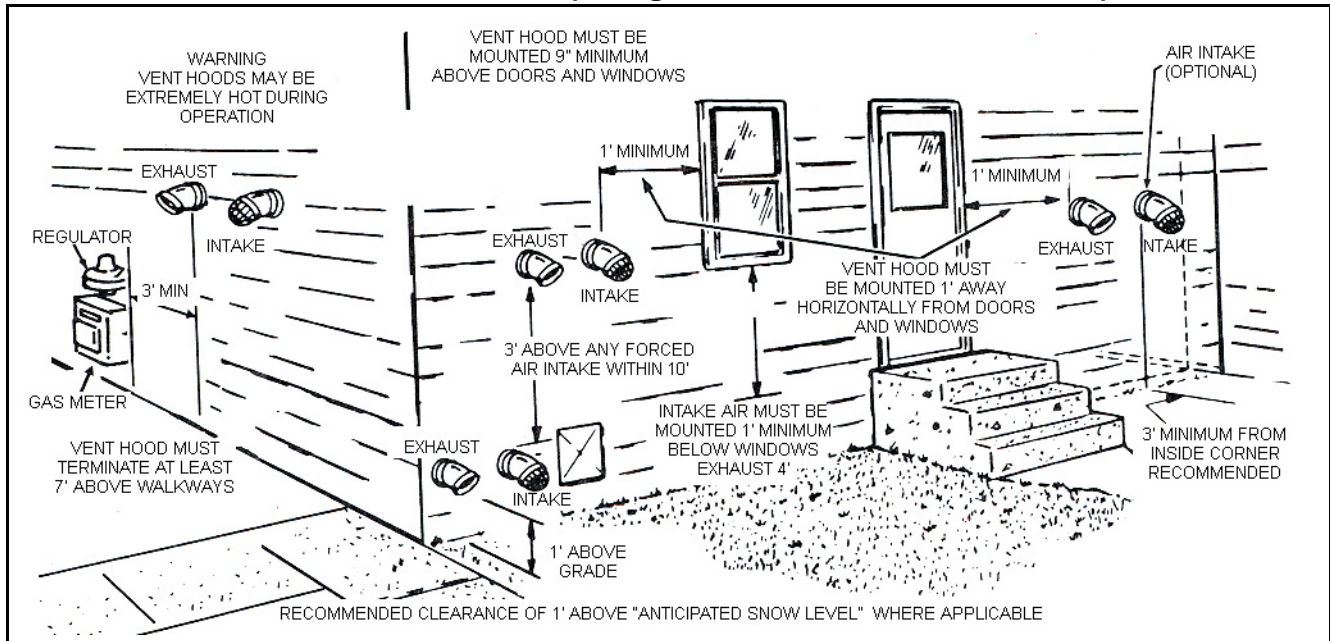

When multiple units are directly vented through a wall, all intake vent terminals must be no lower than the highest exhaust vent terminal.

**CAUTION** DO NOT TERMINATE THE VENTING WHERE NOISE FROM THE EXHAUST OR INTAKE WILL BE OBJECTIONABLE. THIS INCLUDES LOCATION CLOSE TO OR ACROSS FROM WINDOWS AND DOORS. AVOID ANCHORING THE VENT AND INTAKE PIPES DIRECTLY TO FRAMED WALLS, FLOORS OR CEILINGS UNLESS RUBBER ISOLATION PIPE HANGERS ARE USED. THIS PREVENTS ANY VIBRATIONS FROM BEING TRANSMITTED INTO THE LIVING SPACES.

## AIR REQUIREMENTS

### MINIMUM AIR FOR COMBUSTION

10 Cubic Feet of Air Per 1000 BTUH

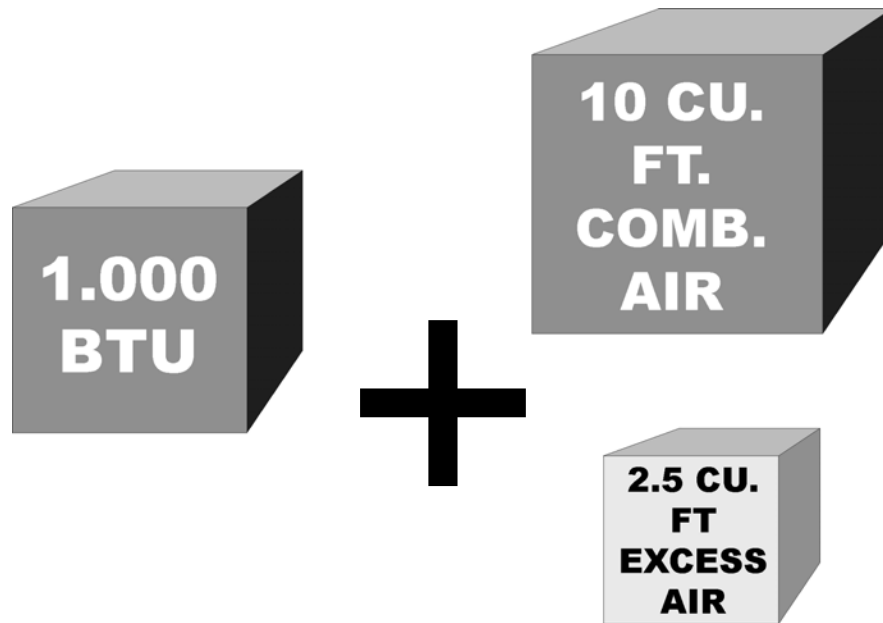

Stoichiometric or theoretical complete combustion requires 10 cubic feet of air per 1000 BTUH of gas input. The National Fuel Gas Code also recommends an additional 2.5 cu.ft. of “excess air”. This 12.5 cu.ft. minimum supply air per 1000 BTUH input applies to natural and propane gas models.

The National Fuel Code also specifies minimum make-up air opening sizes for various building installations (Ref: NFPA 54, ANSI Z223.1, sec 5.3).

### MAKE-UP AIR

#### Direct Vent Installation



This model is approved for direct venting either horizontally or vertically or conventional venting horizontal or vertical. Direct venting avoids using room air for combustion and eliminates the need for additional air intake ducts.

## MAKE-UP AIR Direct Communication



A fresh supply of make-up air for combustion can be supplied to the heater through make-up air openings, which directly communicate with the out of doors. Two openings are required — one within 12 inches of the top of the enclosure and one within 12 inches of the bottom of the enclosure. Each opening shall have a free area of not less than 1 square inch per 4000 BTUH of the total input of all appliances within the enclosure.

The lower opening is primarily providing combustion air. The upper opening is providing vent dilution air and acts as a relief opening for flue gases should the vent become obstructed or a down draft condition occur.

## MAKE-UP AIR Vertical Ducts

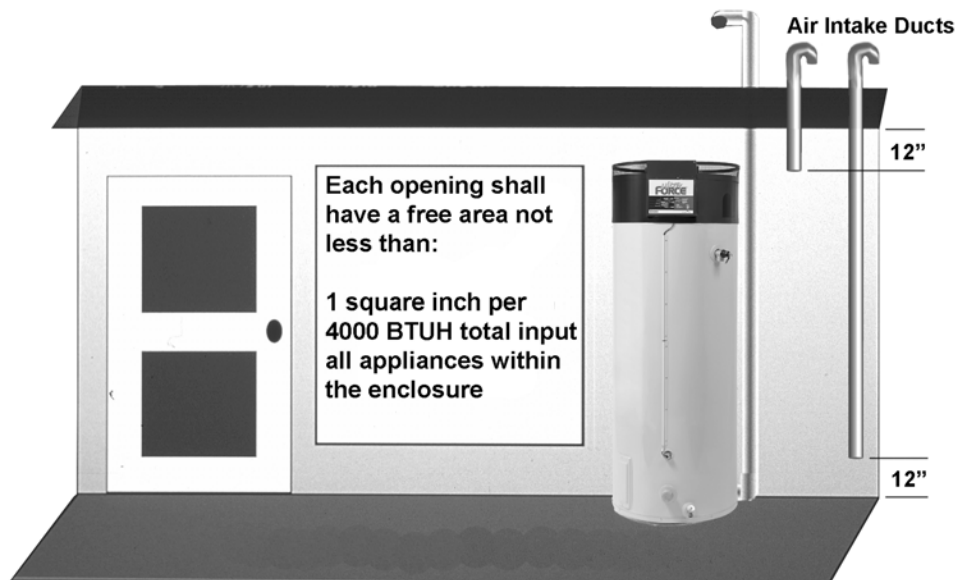

Often it is more practical to install vertical make-up air ducts to the outdoors. Again, two openings are required — within 12 inches (30 cm) of the top of the enclosure and one within 12 inches (30 cm) of the bottom of the enclosure. Each opening shall have a free area of not less than 1 square inch per 4000 BTUH of the total input of all appliances within the enclosure.

## MAKE-UP AIR Horizontal Ducts

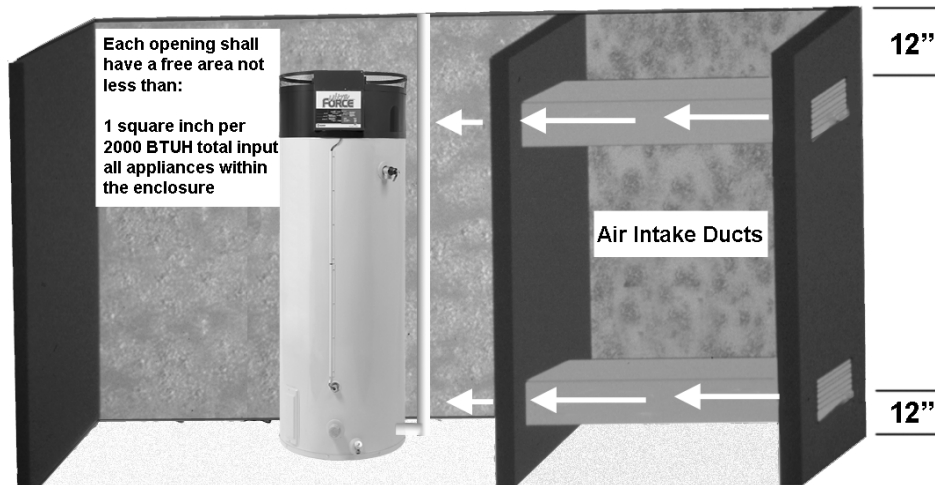

When the heater is installed in an interior room with no roof access for vertical ducts, horizontal make-up ducts should be installed. When using horizontal ducts, two openings are required — within 12 inches (30 cm) of the top of the enclosure and one within 12 inches (30 cm) of the bottom of the enclosure. Each opening shall have a free area of not less than 1 square inch per 2000 BTUH of the total input of all appliances within the enclosure.

## INSUFFICIENT MAKE-UP AIR Backdraft



Insufficient make-up air is a major cause of combustion problems. One common example is in a restaurant installation where exhaust vent equipment was not considered in sizing make-up air requirements. This may result in air being backdrafted by the restaurant exhaust equipment through the heater causing flue gas spillage, flame roll out, improper combustion, inconsistent pilot operation, and/or erratic heater shutdown.

A possible solution to this situation would be to use a SUF with direct venting.

A less common service issue associated with a backdraft or negative pressure room would be the opening or closing of air pressure switches. This may result in erratic or no heater operation.

## CONTAMINATED AIR



Along with adequate make-up air, the quality of the air is important. Contaminants in combustion air can lead to premature heater failure. Vapors from bleaches, soaps, salts, etc. are drawn into the combustion chamber with the make-up air and, once fired, mix with water vapor in the gasses to form extremely corrosive hydrochloric or hydrofluoric acid and other corrosive by-products. Dust drawn in may build up on the blower or clog the main burner ports. Also, be certain to examine the exterior area around the air intake of a direct vent installation for the contaminants.

## FLAMMABLE ITEMS



Flammable items or pressurized containers or any other potentially hazardous articles must never be placed on or adjacent to the heater. Open containers of flammable material should not be stored or used in the same room with the heater or in the area of the exterior air intake of a direct vent installation. Direct venting **does not** eliminate the need to remove flammable or corrosives from the area surrounding the heater.

## MULTIPLE UNIT — WATER PIPING

### PARALLEL PIPING

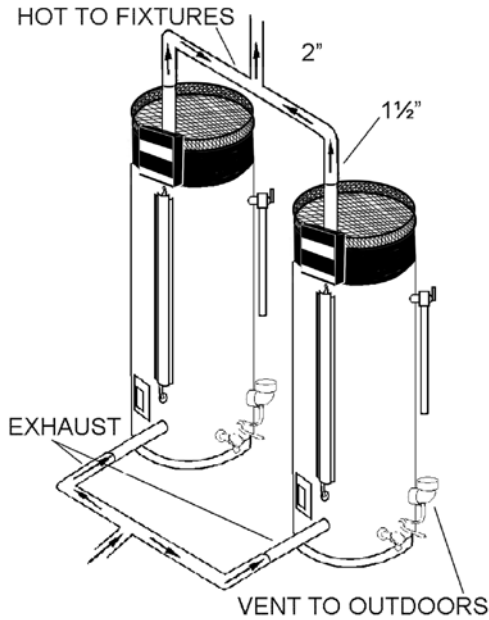

### REVERSE RETURN PIPING

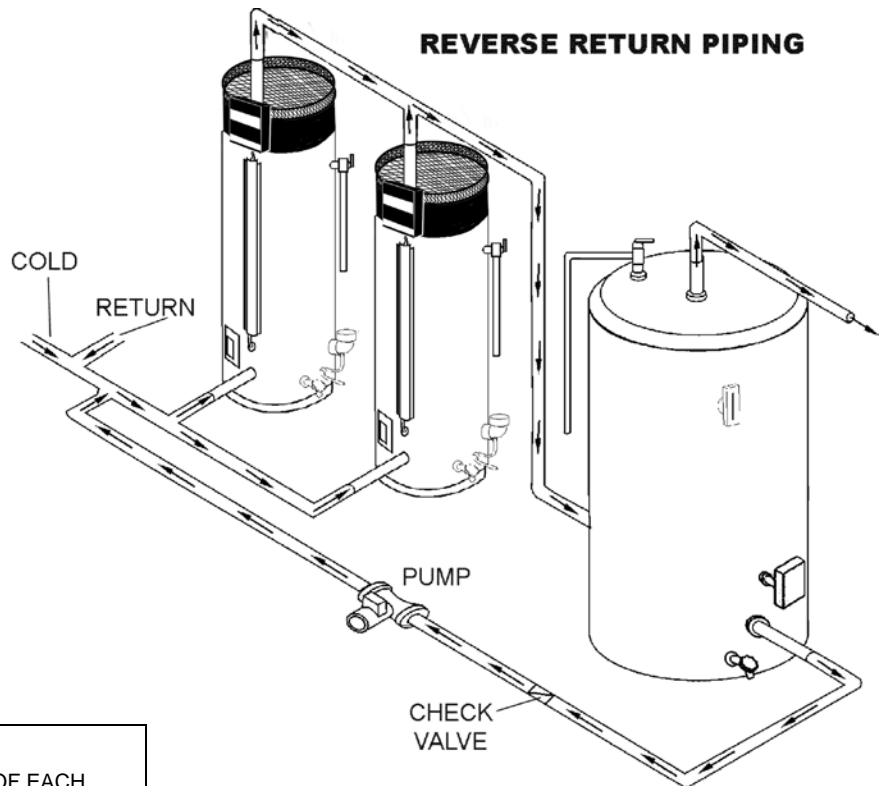

#### NOTES APPLY TO ALL SYSTEMS:

\*ADD GATE VALVES TO INLET AND OUTLET OF EACH UNIT FOR ISOLATION FLEXIBILITY. LOCATE AT THE SAME POINT FROM TEE.

\*\* ADD THERMAL EXPANSION TANK TO COLD WATER SUPPLY IF NECESSARY.

CONDENSATION HOSE MUST BE ALLOWED TO DRAIN.

NOTE: T&P VALVES MUST BE PIPED TO OPEN DRAIN OR PER LOCAL CODE

### PARALLEL PIPING WITH TANK

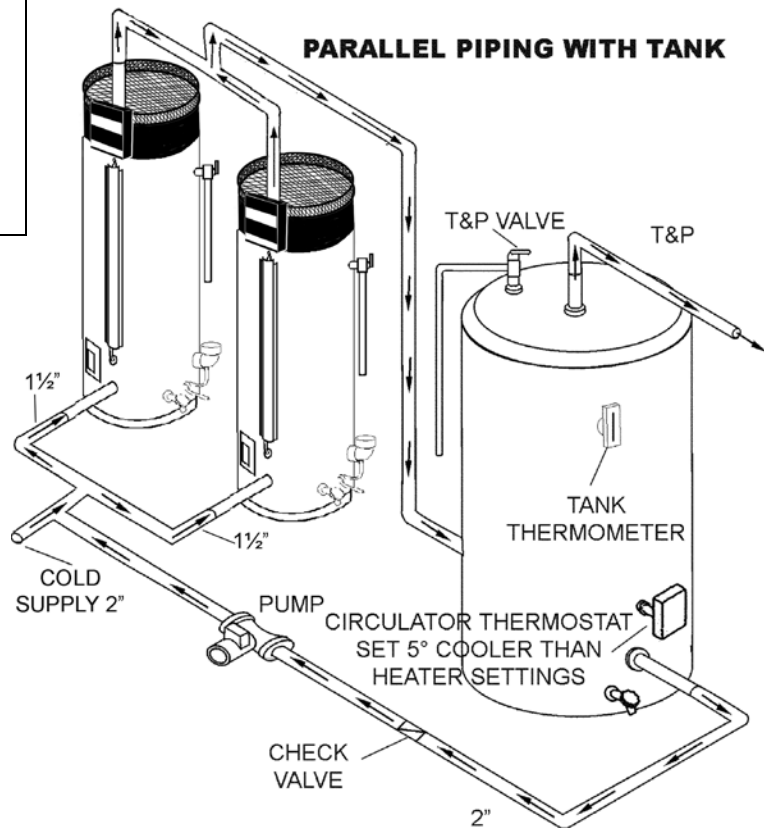

### REVERSE RETURN PIPING WITH TANK

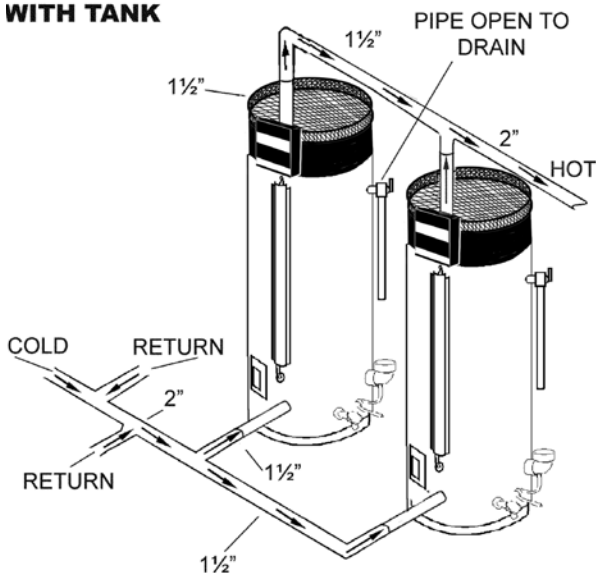

## CONDENSATION

The average dewpoint of natural gas flue products is 127° F. Propane flue products is 119° F. With 70° F ambient air temperature and 180° F stored water temperature, exhaust gas will be approximately 140° F. Recommended starting point for water storage is 120° F.

The extra high thermal efficiency of the SUF will result in condensation in the flue passage. The following answers common questions about this condensation.

**CAN I DRAIN THIS CONDENSATION TO A FLOOR DRAIN?** The “Corrosion Resistance of Cast Iron Soil Pipe” by the Ductile Metals Association (formally the Cast Iron Soil Pipe Institute) states that:

“Internal corrosion of cast iron soil pipe and fittings can be caused by strong acids or other reagents having an acidity of pH 4.3 or less if allowed to contact cast iron pipe for an extended period of time without sufficient dilution to raise the pH value about 4.3. By avoiding low pH discharges, internal corrosion problems can be limited or eliminated, assuring the owner many years of service.”

**WHAT ABOUT THE pH VALUES OF CONDENSATE AND SODA POP?** The pH of the SUF condensate average 4.5 which is approximately 4 times less concentrated than the limit of 4.3 recommended by the DMA. Any water flow in the drain rapidly dilutes the condensate even more. A can of leading carbonated cola drink measured a pH of 2.5 which is 300 times more concentrated than the SUF condensate.

**WHAT DOES THE pH SCALE MEAN?** The pH value is a measure of acidity of alkalinity. A pH of 7 is neutral. Numbers from 7 to 1 indicate increasing acidity and numbers from 7 to 14 indicate increasing alkalinity. The pH scale is similar to the Richter scale used to measure earthquakes. Each number indicates a change of 10 times the concentration of the previous value. A pH 6 is 10 times more concentrated than a pH 7, a pH 5 is (10x10) 100 times pH 7 and pH 4 is (10x10x10) 1,000 times pH 7, etc.

**WHAT ABOUT CONDENSATE NEUTRALIZERS?** Condensate neutralizers are usually not necessary. A condensate neutralizer is easy to make by filling a short length of 2” or 3” PVC pipe with landscape marble chips, capping it and installing it in series with the condensate drain of the equipment. Most commercial neutralizers are off the market because of poor demand for the product. Condensation from the exhaust vent piping and tank internal flue way **must** be allowed to drain. A “blocked flue” indication will often be your first indication that condensate is **not** draining.

# OPERATION

## SEQUENCE OF OPERATION

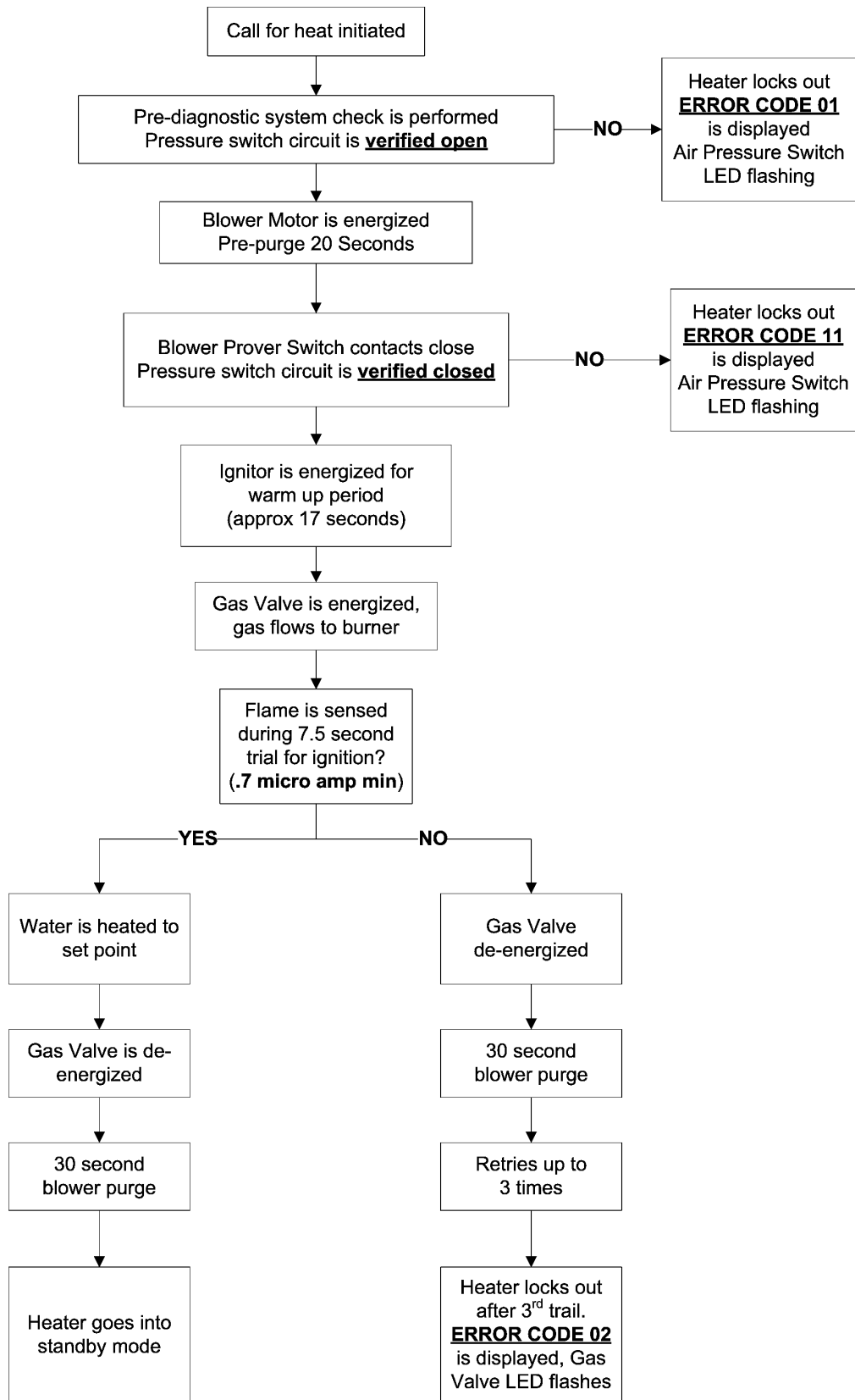



## CONTROLS

### NORMAL INDICATIONS / READINGS / SETTINGS

#### During Call for Heat

- On/Off switch in the “on” position
- Water Temperature F° — current average tank water temperature displayed
- 120 VAC LED light on
- 24 VAC LED light on
- High Limit/Vent Switch LED light on
- Blower (while blower is running) LED light on
- Air Pressure Switch (while blower is running) LED light on
- Control Status LED light on
- Gas Valve (during ignition period and heating cycle) LED light on

#### DISPLAY PANEL (CONTROL PANEL)



The water temperature inside the tank must be below the current temperature setting to activate a call for heat. Pressing the Set/Reset button approximately 4 – 6 seconds after powering up the water heater will reveal the current temperature setting. See the instructions below for how to view or change temperature settings.

#### Power On Display Sequence / Indication

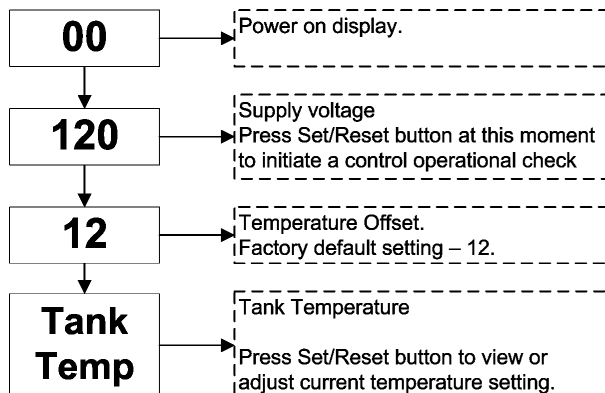

#### To View Or Change Temperature Settings

**Press the Set/Reset button once to view the current temperature setting.**

**Press and hold the Set/Reset button down to change the current setting.**

*When pressed and held down it will raise/lower the setting, quickly releasing and pressing down/holding again will switch between raising and lowering. When the desired setting is reached release the button.*

*The control must satisfy a call for heat with the new setting for the new setting to remain in memory. If the water heater does not satisfy a call for heat with the new setting, the new setting is lost and the previous setting remains in effect.*

## CIRCUIT BOARDS

### DISPLAY CIRCUIT BOARD

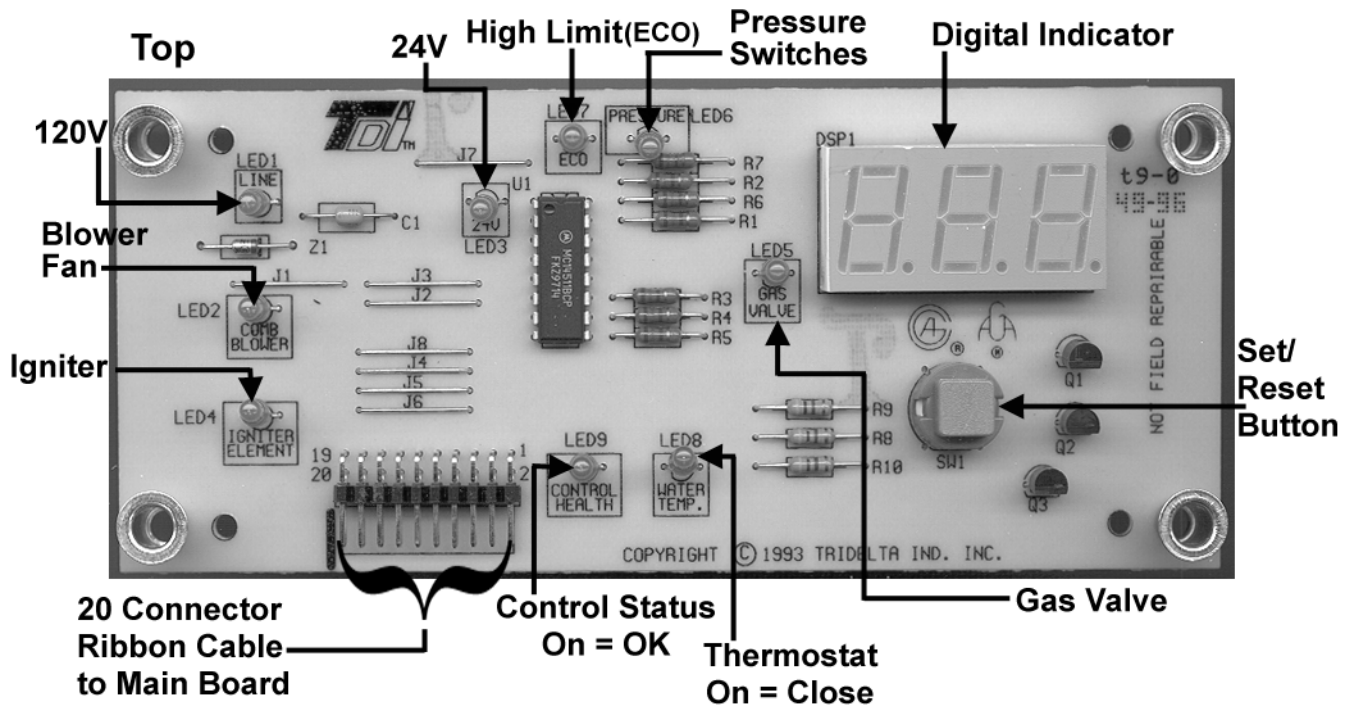

### IGNITION CIRCUIT BOARD

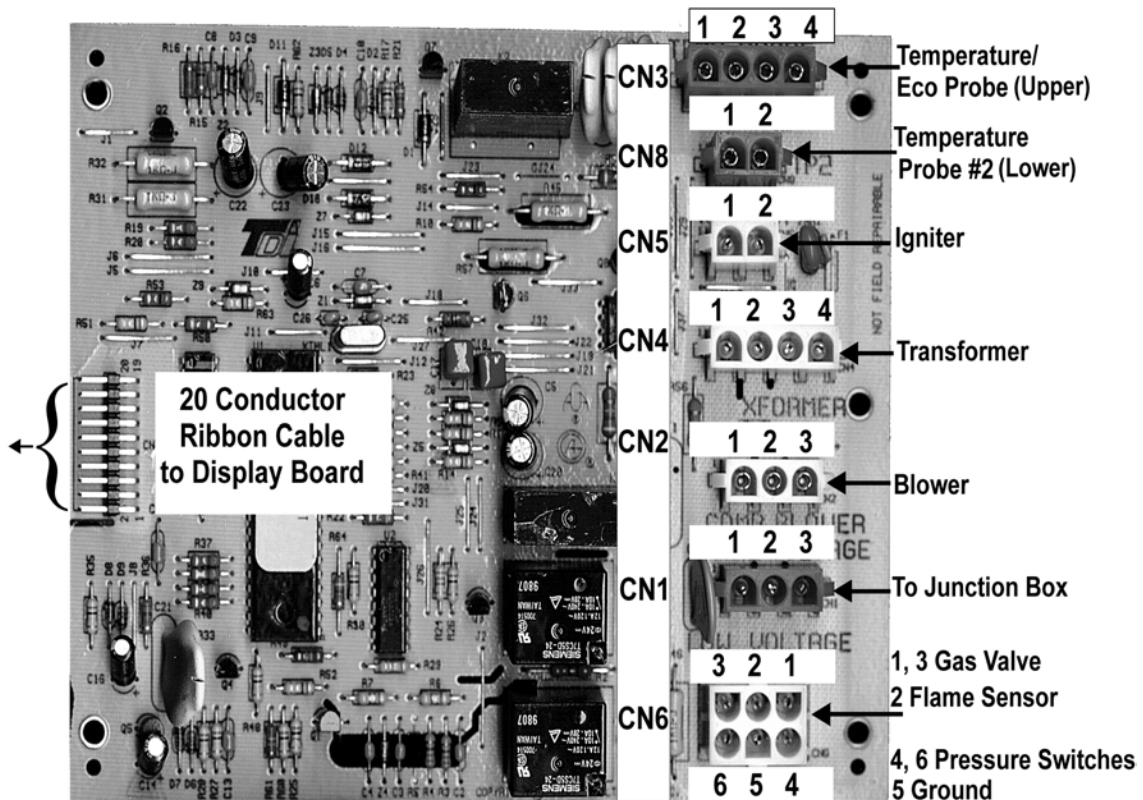

# TROUBLESHOOTING

## PRE-SERVICE TIPS

**CHECK THAT:**

- Insure 120 VAC power supply has correct polarity — check neutral (white) wire to ground with volt meter. It should read “0” volts.
- Tank is full of water
- Exhaust and intake vent do not exceed allowable limits
- All plugs into boards are secure
- Condensate hose is drained and open
- Proper (natural or propane) gas is supplied

### 120 VAC TO CONTROL

**STEP 1**

**120 VAC TO CONTROL BOARD**

**STEP 1: CHECK FOR 120 VAC TO CONTROL BOARD CN1 TERMINAL.**

Condition:

- Disconnect plug from CN1 terminal.
- On/Off switch is on.

Check for 120 VAC black wire terminal white wire on plug.

IF...	THEN
120 VAC is not present	check On/Off switch, turn switch on, replace On/Off switch if defective, restore power to the water heater.
120 VAC is present	reconnect CN1 plug, continue to Step 2.

## TRANSFORMER

### STEP 2 120 VAC TO TRANSFORMER

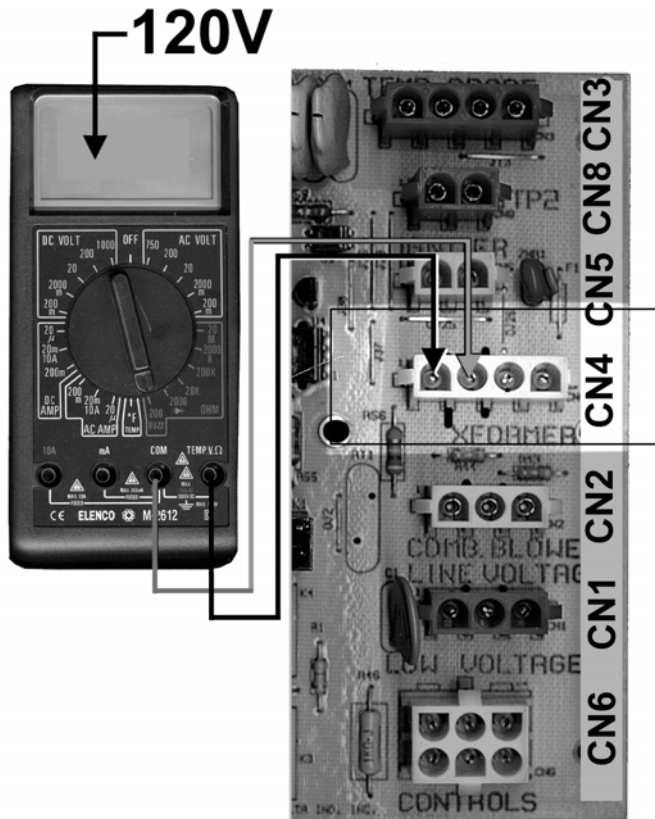

**STEP 2:** CHECK FOR 120 VAC TO TRANSFORMER FROM PIN 1 AND 2 ON CONTROL BOARD CN4 TERMINAL.

Condition:

- Disconnect CN4 plug from control board.
- On/Off switch is on.

Check for 120 VAC between pin 1 and 2 at CN4 on the control board as illustrated above. Perform this test with the CN4 plug disconnected and the On/Off switch turned on.

IF...	THEN
120 VAC is not present	check CN1 plug connection replace control board if Step 1 has been performed and results were successful.
120 VAC is present	reconnect CN4 plug to control board, continue to Step 3.

## TRANSFORMER (CONTINUED)

### STEP 3 24 VAC FROM TRANSFORMER

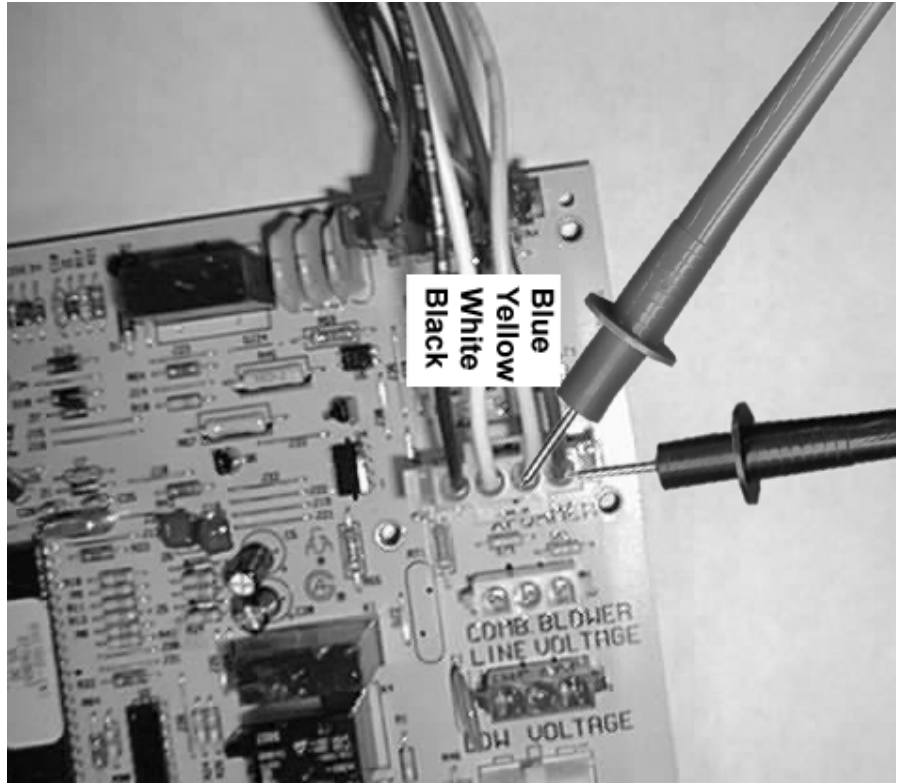

**STEP 3:** CHECK FOR 24 VAC AT TRANSFORMER CN4 PLUG ON CONTROL BOARD.

Condition:

- CN4 is plugged into control board.
- On/Off switch is on.

Insert meter probes into back of CN4 plug on pins 3 and 4 (blue and yellow wires) with CN4 plugged in and power on.

IF...	THEN
24 VAC is not present	replace transformer if Steps 1 and 2 were performed and results were successful.
24 VAC is present	continue to Step 4.

## ECO CHECK

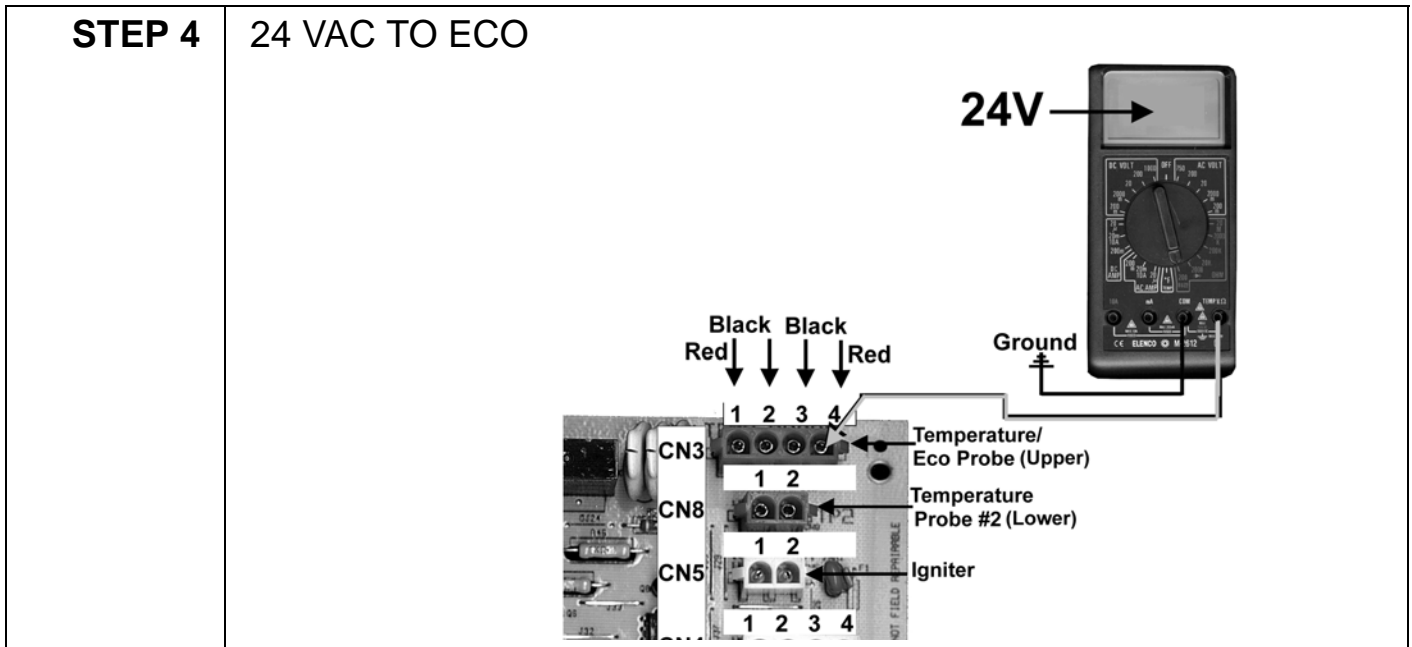

**STEP 4:** CHECK FOR 24 VAC BETWEEN PIN 4 ON CONTROL BOARD TERMINAL CN3 AND GROUND.

Condition:

- Disconnect CN3 plug from control board.
- On/Off switch is on.

Check for 24 VAC between pin 4 of the CN3 terminal on the control board and ground.

IF...	THEN
24 VAC is not present	replace the control board if Steps 1, 2, and 3 have been performed and the results were successful.
24 VAC is present	continue to Step 5.

## ECO CHECK (CONTINUED)

<b>STEP 5</b>	<p style="font-size: 1.2em; margin: 0;">24 VAC FROM ECO</p> <div style="text-align: center; margin-top: 20px;"> </div>
---------------	--

**STEP 5:** CHECK FOR 24 VAC BETWEEN PIN 1 ON CN3 PLUG AND GROUND.

Condition:

- Reconnect CN3 plug to control board.
- On/Off switch is on.

Insert one meter probe into the back of CN3 plug pin 1, check for 24 VAC between here and ground with CN3 plugged in and power on. (See illustration above for pin number locations.)

IF...	THEN
24 VAC is not present	make sure water temperature in tank is below 160° F, press Set/Reset button on display panel, replace upper temperature/ECO probe if tank water temperature is below 160 and Step 4 has been performed and results were successful.
24 VAC is present	continue to Step 6.

## TEMPERATURE PROBE

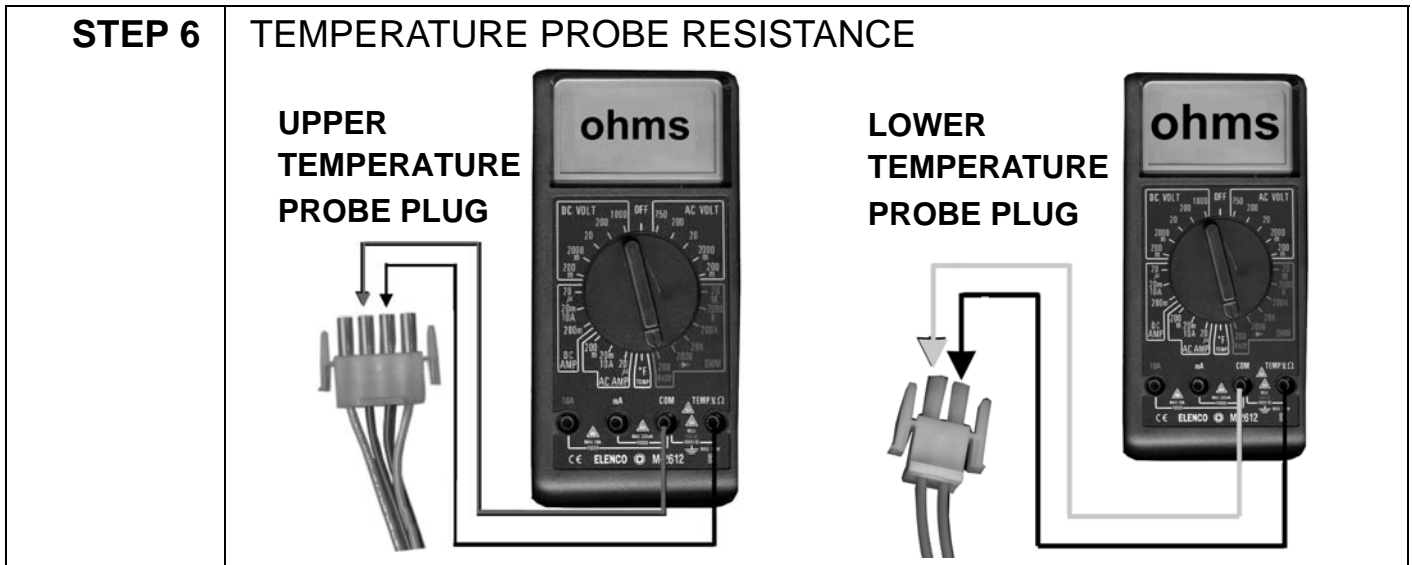

**STEP 6:** CHECK RESISTANCE OF THERMISTOR IN UPPER AND LOWER TEMPERATURE PROBES.

Condition:

- Disconnect CN3 and CN8 plugs from control board.
- On/Off switch is off.
- Multimeter is set to lowest ohms scale above expected resistance.

Check resistance between black wire connects on CN3 and CN8 plugs as shown in illustration above.

IF...	THEN
ohm reading does not approximately correspond to table at given temperatures	replace temperature probe if thermistor is open, shorted, or resistance value is off significantly.
ohm reading does approximately correspond to table at given temperatures	continue to Step 7.

WATER TEMP		OHMS RESISTANCE
°C	°F	
3	40	26,435
21	70	11,974
37.5	100	5,862
49	120	3,780
54.5	130	3,066
60	140	2,503
71	160	1,698
82	180	1,177

**NOTE:** The upper and lower temperature probes contain thermistors which are heat sensitive resistors. The control board interprets changes in thermistor resistance as changes in water temperature.

These thermistors are very reliable and should only be replaced when:

The resistance test indicates an “open” (infinite resistance) or a “direct short” (no resistance) circuit.

The nature of the service problem is temperature control and the resistance readings are significantly off when compared to the values in the table here at the given temperature.



## PRESSURE SWITCH CONTINUITY

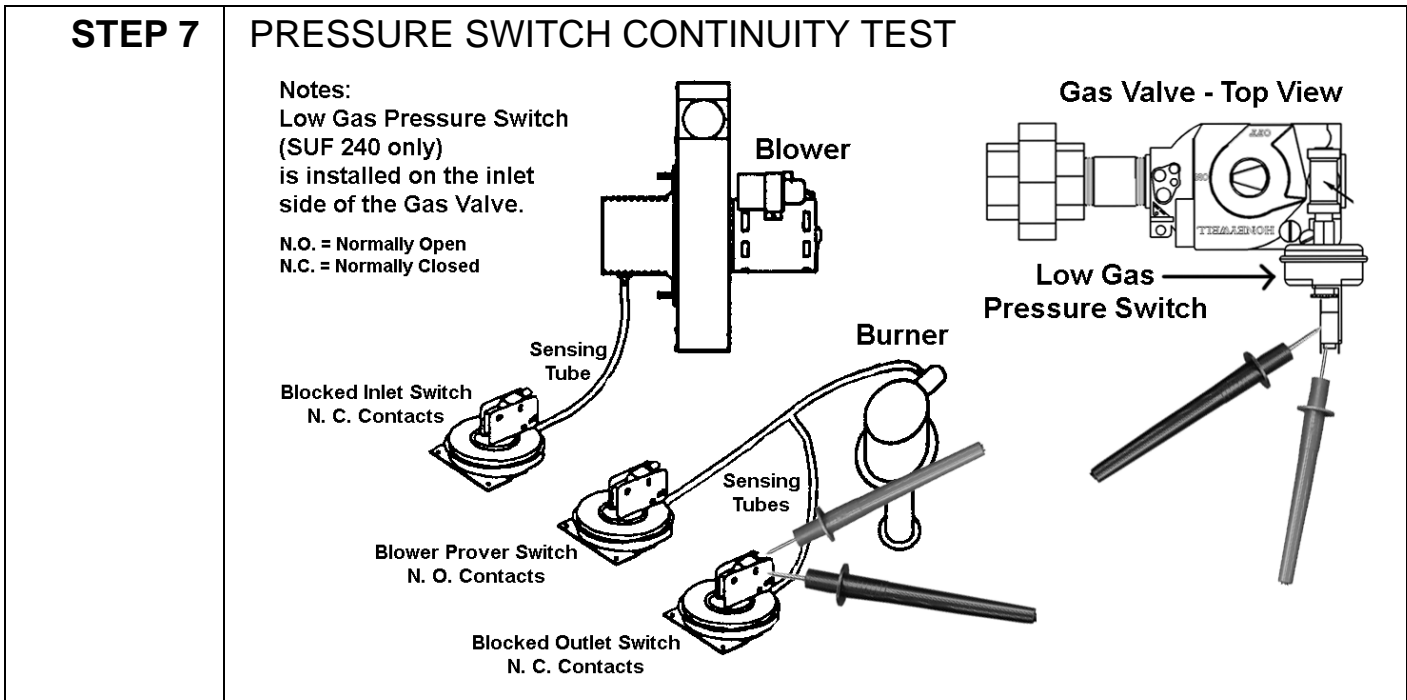

**STEP 7: CHECK FOR CONTINUITY BETWEEN PRESSURE SWITCH TERMINALS WITH WIRES REMOVED.**

Condition:

- On/Off switch is off.
- All wires are disconnected from all pressure switches.
- Multimeter is set to lowest ohms scale.

IF...	THEN
blocked inlet switch <b>does not</b> show continuity	replace switch.
blocked inlet switch <b>does</b> show continuity	continue.
blower proving switch <b>does</b> show continuity	replace switch.
blower proving switch <b>does not</b> show continuity	continue.
low gas pressure switch <b>does not</b> show continuity	check for minimum supply gas pressure of <b>5.0" W.C. natural gas</b> <b>9.0" W.C. LP gas</b> replace switch if gas pressures are above these minimums.
low gas pressure switch <b>does</b> show continuity	continue.
blocked outlet pressure switch <b>does not</b> show continuity	replace switch.
blocked outlet pressure switch <b>does</b> show continuity	reconnect all wires to pressure switches; continue to Step 8.

## BLOWER

### STEP 8 120 VAC TO BLOWER

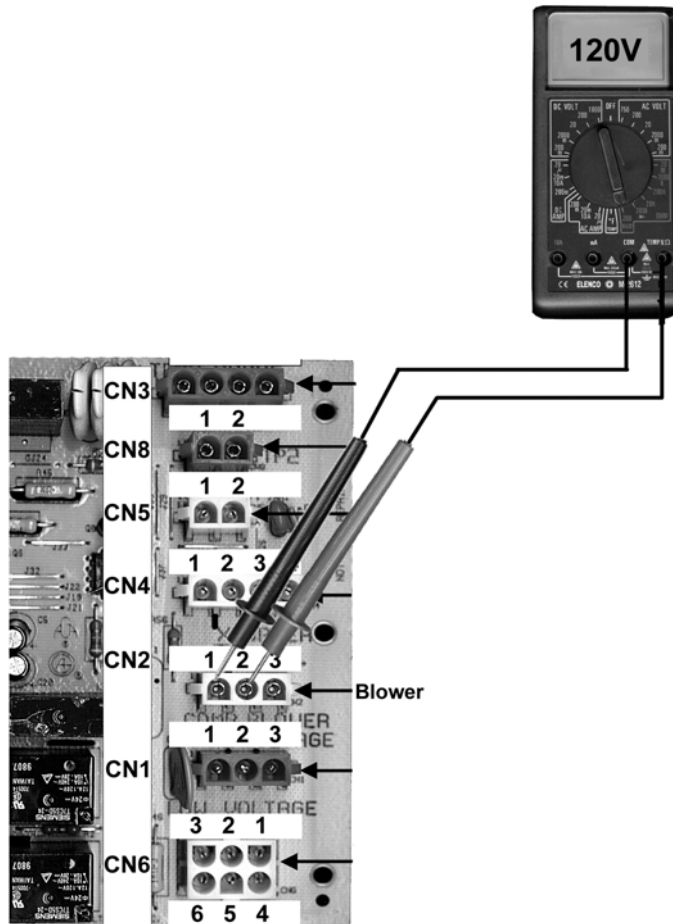

**STEP 8:** CHECK FOR 120 VAC TO BLOWER FROM CN2 PLUG PIN 1 AND 2.

Condition:

- Reconnect all plugs to control board.
- On/Off switch is on.
- Call for heat is activated.

Insert meter probes into back of CN2 plug on pins 1 and 2 with CN2 plugged in, power on, and a call for heat activated.

IF...	AND	THEN
120 VAC is not present		replace the control board if call for heat is active and Step 7 has been performed and results were successful — continue to Step 9A.

## PRESSURE SWITCH PERFORMANCE

### STEP 9A

TAKE AIR AND GAS PRESSURE READINGS.



Blower prover and blocked outlet pressure

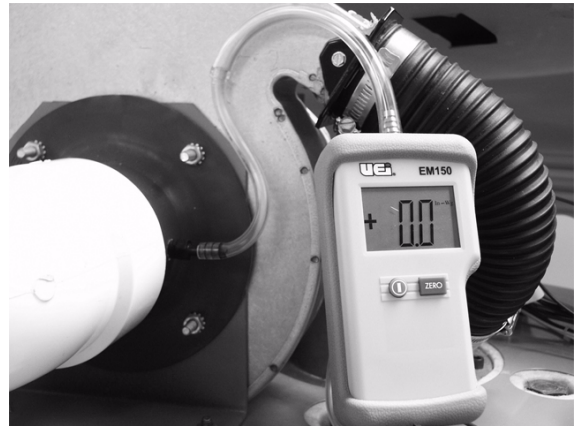

Blower inlet pressure

**STEP 9A:** CHECK PRESSURE AT SENSING PORTS ON BURNER, BLOWER INLET AND GAS VALVE.

Condition:

- All wires are reconnected to all pressure switches.
- On/Off switch is on.
- Call for heat is activated.
- Blower is running during trial for ignition.

Remove the air pressure sensing tubes from the sensing ports on the blower inlet and the burner. Using a digital manometer take a pressure reading with the blower running during a call for heat at both of these sensing ports. Take a supply gas pressure reading on the inlet side of the gas valve as outlined in Step 13.

Record all 3 pressure readings and have them on hand. Continue to Step 9B.

### AMBIENT ROOM AIR PRESSURE

**NOTE:** One side of the internal diaphragms on these pressure switches are vented to the room atmosphere. Due to this construction a negative or positive room air pressure can cause erratic switch operation and the water heater to shut down. If you suspect a pressure imbalance between the equipment room and the outdoor atmosphere, “zero” or calibrate your digital manometer to the equipment room ambient air pressure. With the manometer still on and calibrated to the equipment room air pressure take the manometer outdoors. If the pressure reading changes significantly you may have a pressure imbalance between the equipment room and the outdoor atmosphere. This pressure imbalance may need to be corrected before the water heater will operate properly.

Insure the combustion/make-up air openings into the equipment room are properly sized. Check for leaks in ductwork on any nearby air handling equipment. If there is a kitchen vent hood installed in the building, insure it is properly balanced. Missing or worn fan belts on make up air fans to vent hoods can cause negative air pressure throughout the building.

Direct vent installations DO NOT eliminate this potential problem.

## PRESSURE SWITCH PERFORMANCE (CONTINUED)

### STEP 9B

### PRESSURE SWITCH CONTINUITY TEST — OPERATIONAL



Air pressure switches



Low gas pressure switch

### STEP 9B: CHECK FOR CONTINUITY BETWEEN PRESSURE SWITCH TERMINALS WITH WIRES REMOVED AND BLOWER RUNNING.

**Condition:**

- All wires are disconnected from all pressure switches — ends are taped off.
- On/Off switch is on.
- Call for heat is activated.
- Blower is running during trial for ignition.
- Multimeter is set to lowest ohms scale.

The wires disconnected are energized with 24 VAC from the control board. Do not allow these wires to touch ground — use electrical tape to insulate wire connects during this test.

Check for continuity with an ohm meter between terminals on all pressure switches with the wires removed and the blower running during a trial for ignition. Restart the water heater as needed.

The pressure switches are wired together in a “series” circuit. For the water heater to continue to fire and satisfy a call for heat the control board must sense a closed pressure switch circuit.

IF...	THEN
continuity is not present between terminals on one or more pressure switches — the switch contacts are open.  compare the pressure reading recorded in Step 9A to the value given for that switch in the table on page 34.  compare to value for correct Model and Series number in table.	if the pressure recorded in Step 9A <u>is within</u> the value shown in the table for the switch contacts to remain closed — replace the pressure switch.  if the pressure recorded in Step 9A <u>is not within</u> the value shown in the table for the switch contacts to remain closed — check for/clear any restrictions in the vent and/or air intake piping, check for an excessive number of elbows or equivalent feet of pipe used in the vent and/or air intake piping.  check for/restore minimum supply gas pressure — Step13.
continuity is present.	continue to Step 10.

## 120 VAC TO IGNITOR

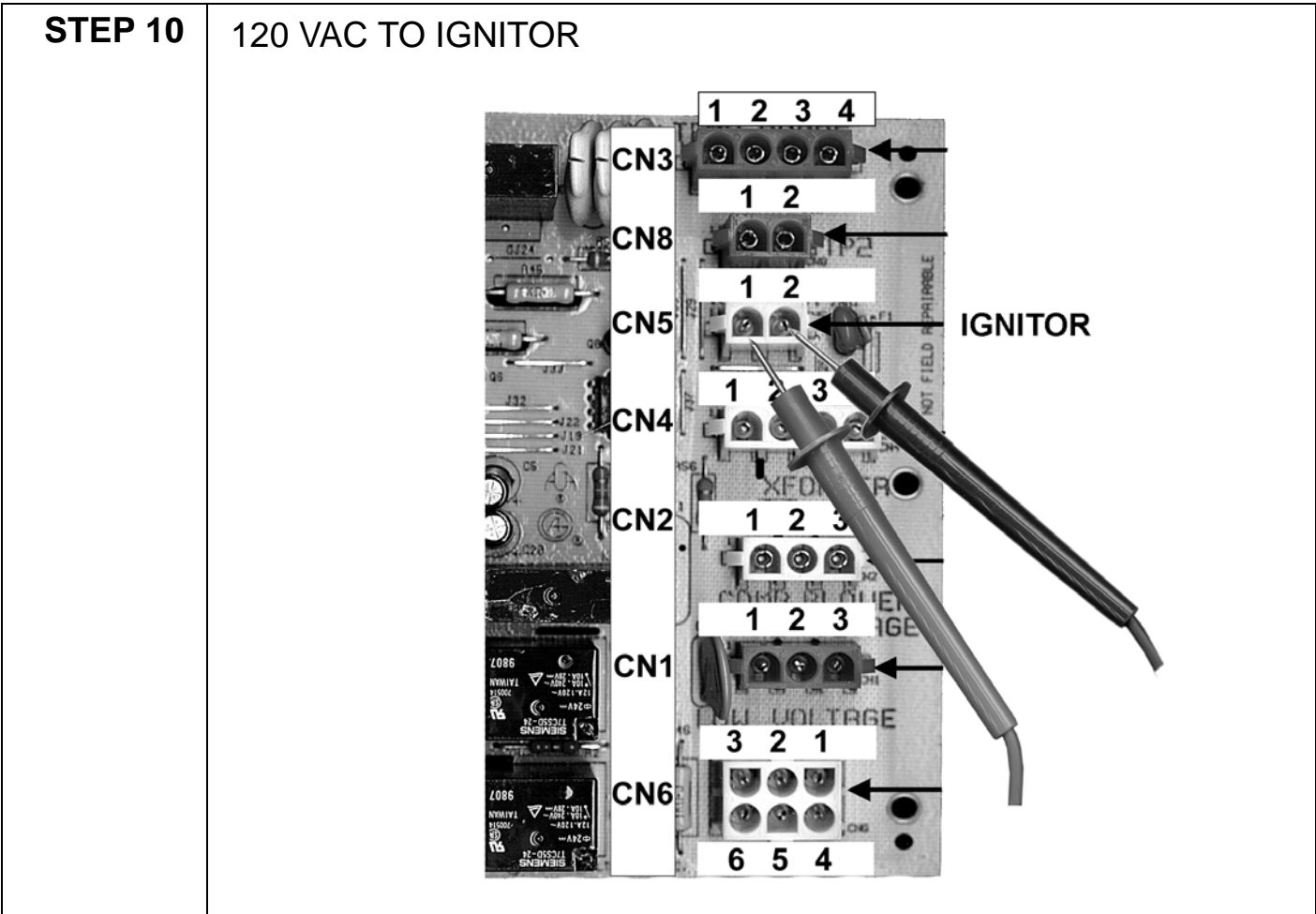

**STEP 10:** CHECK FOR 120 VAC TO IGNITOR FROM PIN 1 AND 2 ON CONTROL BOARD TERMINAL CN5.

Condition:

- Disconnect CN5 plug from control board.
- On/Off switch is on.
- Call for heat is activated.
- Perform test during ignitor warm up period.

IF...	THEN
120 VAC is not present	replace the control board if Steps 7 through 9B have been performed and results were successful.
120 VAC is present	continue to step 11.

## IGNITOR RESISTANCE

**STEP 11**

**IGNITOR RESISTANCE CHECK**

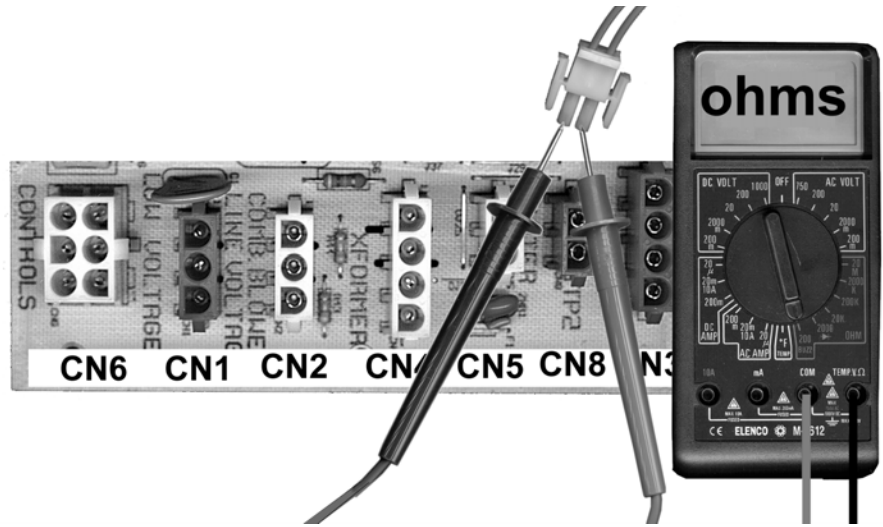

**STEP 11:** CHECK RESISTANCE BETWEEN TWO WIRE CONNECTS AT CN5 IGNITOR PLUG END.

Condition:

- On/Off switch is off.
- Disconnect CN5 ignitor plug from circuit board.
- Multimeter is set to lowest ohms scale above 300 ohms.

IF...	THEN
ohms reading taken is not between 50 – 300 ohms	replace the ignitor.
ohms reading taken is between 50 – 300 ohms	reconnect CN5 plug, continue to Step 12.

## GAS VALVE TEST

### STEP 12 24 VAC TO GAS VALVE

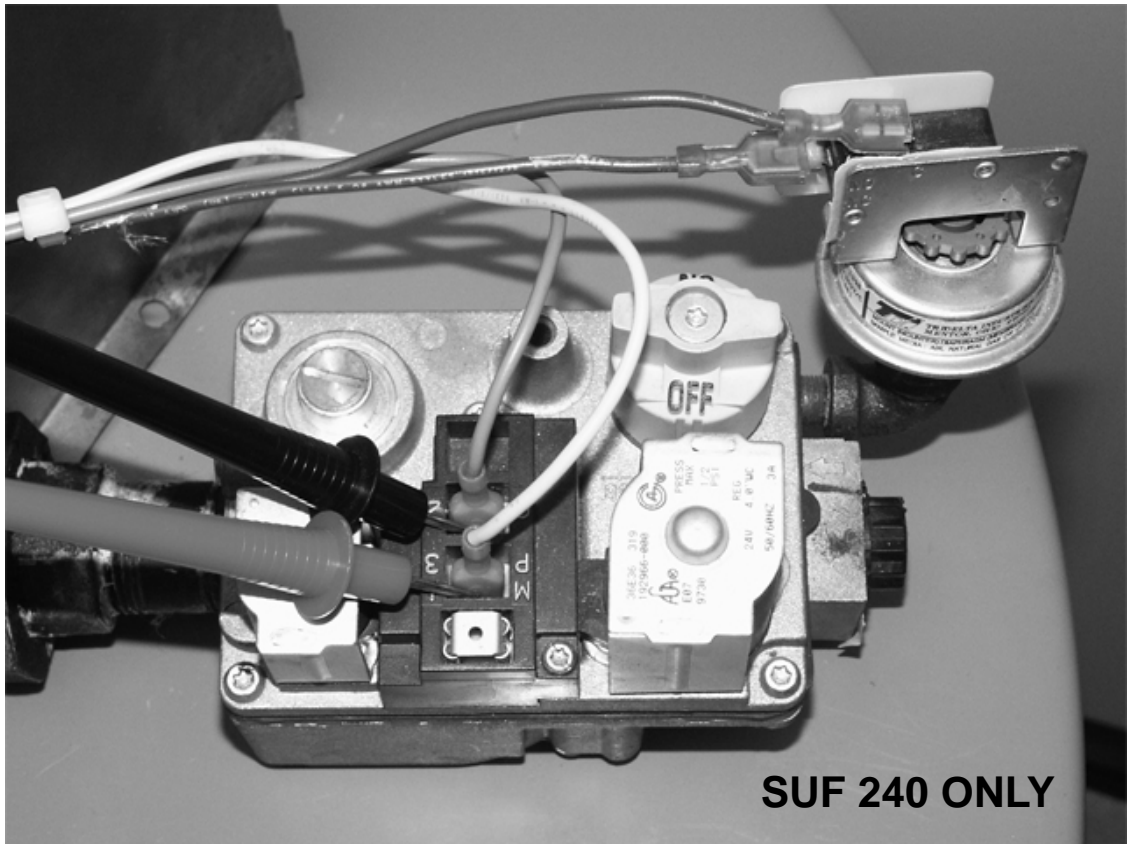

**STEP 12:** CHECK FOR 24 VAC TO GAS VALVE DURING TRIAL FOR IGNITION.

Condition:

- All wires are reconnected.
- On/Off switch is on.
- Call for heat is activated.
- Perform test at end of ignitor warm up period.

Touch meter probes to wiring terminals on gas valve with wires from control board still connected during the ignitor warm up period.

IF...	AND	THEN
24 VAC is not present to gas valve		replace control board if Step 9A and 9B have been performed and results were successful.
24 VAC is present	gas does not flow to burner	check for/restore supply gas; check for/clear any restriction in the gas train; replace the gas valve if the valve will not open with 24 VAC applied.
24 VAC is present	gas does flow to burner	continue to Step 13.

## GAS PRESSURE CHECK

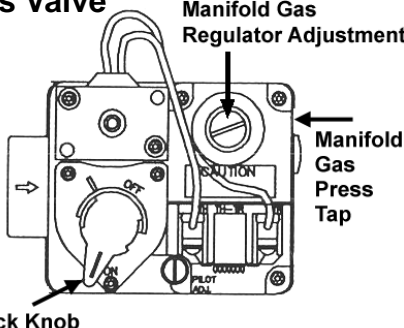
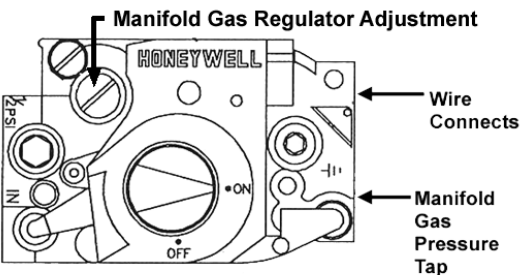
<b>STEP 13</b>	<p style="text-align: center;"><b>SUPPLY GAS PRESSURE TEST</b></p> <div style="display: flex; justify-content: space-around;"> <div style="text-align: center;"> <p><b>SUF 150, 199 Propane SUF 240 Natural Gas Valve</b></p>  </div> <div style="text-align: center;"> <p><b>SUF 150, 199 Natural Gas Valve</b></p>  </div> </div>
----------------	--

**STEP 13: CHECK AND ADJUST SUPPLY GAS PRESSURE.**

Attach manometer or gas pressure gauge to pressure tap on gas valve or use adapter to check pressure ahead of valve as near as possible to valve. All appliances being served by this gas supply line should be operating.

IF...	THEN
supply gas pressure is not between 5.0 and 14" W.C. natural gas or 11.0 and 14" W.C. propane	adjust supply gas pressure (Recommended supply minimum is 7.0" W.C. for natural gas models)
proper supply gas pressure is present	continue to Step 14.

<b>STEP 14</b>	<b>MANIFOLD GAS PRESSURE TEST</b>
----------------	-----------------------------------

**STEP 14: CHECK AND ADJUST MANIFOLD GAS PRESSURE.**

IF...	THEN
manifold gas pressure is not: natural gas models 3.5" W.C. ± 0.3" – SUF 155 & 199 4.0" W.C. ± 0.3" – SUF 240 propane gas models 10.0" W.C. ± 0.3" – all propane gas models.	adjust manifold gas pressure to values given for model and fuel type (within 0.3" W.C. tolerance) if manifold gas pressure cannot be adjusted to maintain values given (within 0.3" W.C. tolerance) replace gas valve.
manifold gas pressure is within tolerances given above	ignition should occur.



## COMPONENT INFORMATION

FLAME SENSING ROD				
PART NUMBER	FLAME SENSING CURRENT		COMMENTS	
192478	0.7 Micro Amp ( $\mu$ )		SUF 150, 199, & 240	
HOT SURFACE IGNITOR (HSI)				
PART NUMBER	VOLTAGE	AMP	OHMS COLD	COMMENTS
192638	120 VAC	1.0	50 – 300	SUF 150, 199, & 240

## ORIFICE TABLE

ORIFICE TABLE				
SUF MODEL	MAIN BURNER ORIFICE NO.	MAIN ORIFICE SIZE INCHES	AIR ORIFICES PT. NO.	AIR ORIFICE SIZE — INCHES
150	192477-1	0.235	192450-1	0.875
199	192477-0	0.304	192450-0	1.031
240	192477-2	0.360	192450-2	1.196
150 Prop	192477-5	0.141"	192450-5*	0.872
199 Prop	192477-4	0.166"	192450-4*	1.150

\* -4 and -5 stamped with "P" for Propane

**NOTE :** Hex head of main burner orifice is upstream end — gas flows out of tapered end.

## PRESSURE SWITCHES

### PRESSURE SWITCH LAYOUT

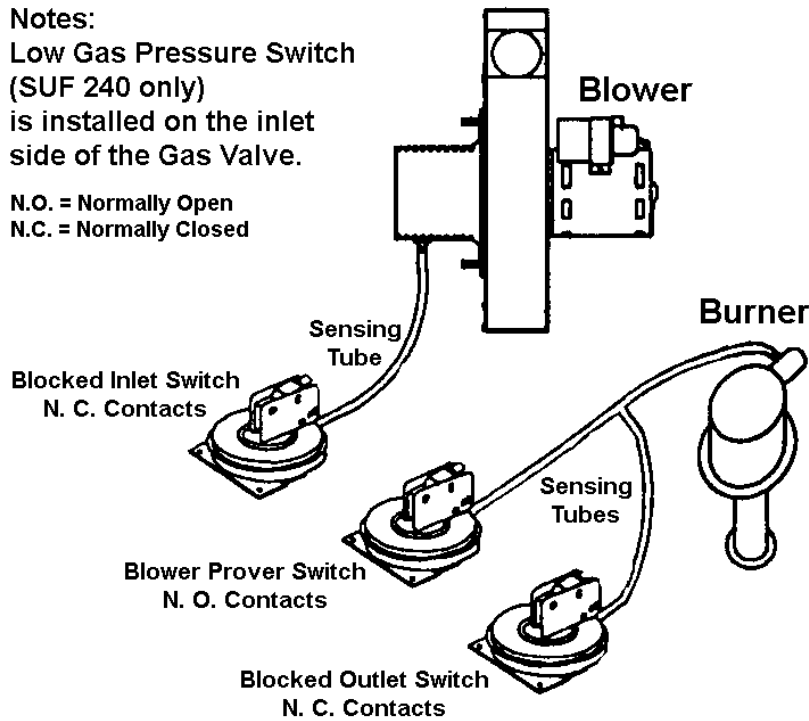

### PRESSURE SWITCH WIRING

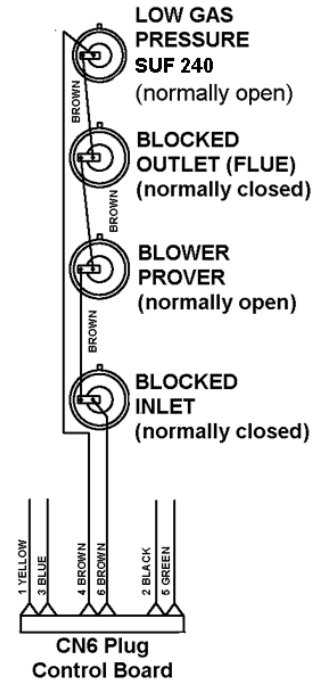

### GAS VALVE

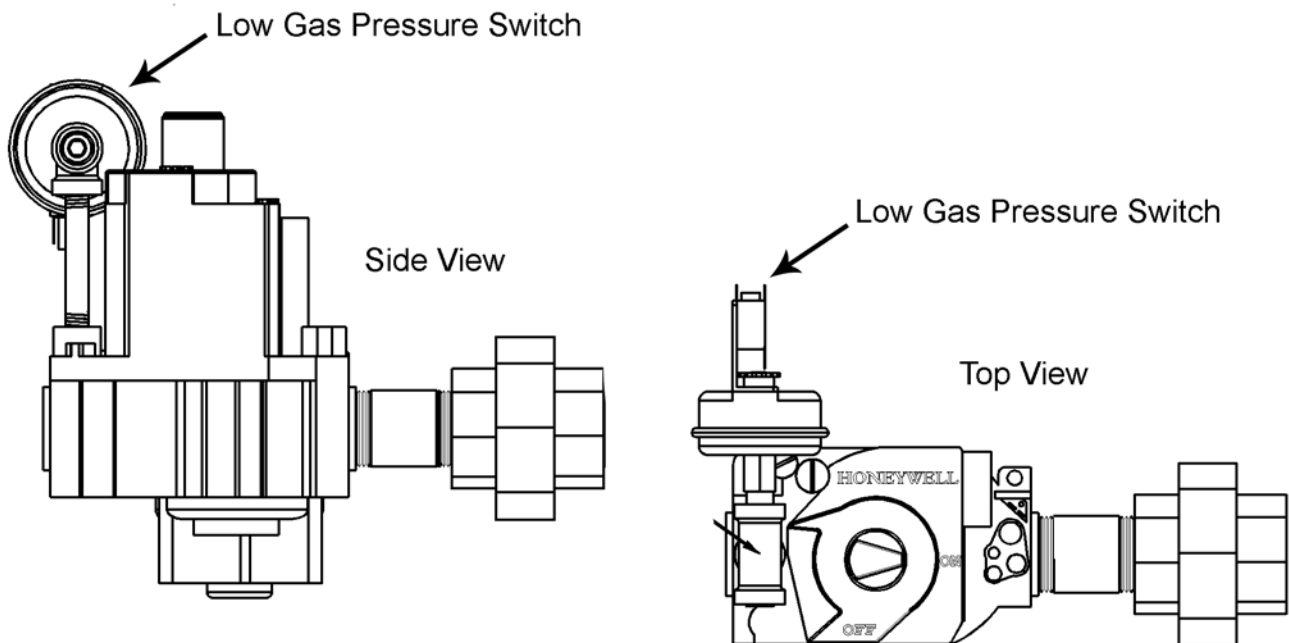

## PRESSURE SWITCHES (CONTINUED)

PRESSURE SWITCHES PART NUMBER / ACTIVATION PRESSURE†				
Model	Blocked Inlet Normally Closed Opens on a fall	Blower Prover Normally Open Closes on a rise	Low Gas Pressure Normally Open Closes on a rise	Blocked Outlet Normally Closed Opens on a rise
<b>SUF 150</b>	193363-000 / -0.76"	194706-000 / +1.00"	N/A	193362-000 / +2.60"
	193355-000 / -1.80"	194706-000 / +1.00"	N/A	193357-000 / +4.00"
	193355-000 / -1.80"	194706-000 / +1.00"	N/A	193357-000 / +4.00"
<b>SUF 199</b>	193363-000 / -0.76"	194706-000 / +1.00"	N/A	193364-000 / +2.87"
	193356-000 / -2.00"	194706-000 / +1.00"	N/A	193357-000 / +4.00"
	193356-000 / -2.00"	194706-000 / +1.00"	N/A	193357-000 / +4.00"
<b>SUF 240</b>	193361-000 / -0.77"	194706-000 / +1.00"	191149-005 / +5.20"	193357-000 / +4.00"

†. Pressure values are given in inches of water column pressure ("W.C.).

Negative pressure values in this table are preceded by a "-" minus sign and indicate pressure below atmospheric; in a vacuum. Positive pressures are preceded by a "+" plus sign and indicate pressure above atmospheric.

# WIRING DIAGRAMS

SUF 150, 199, 240

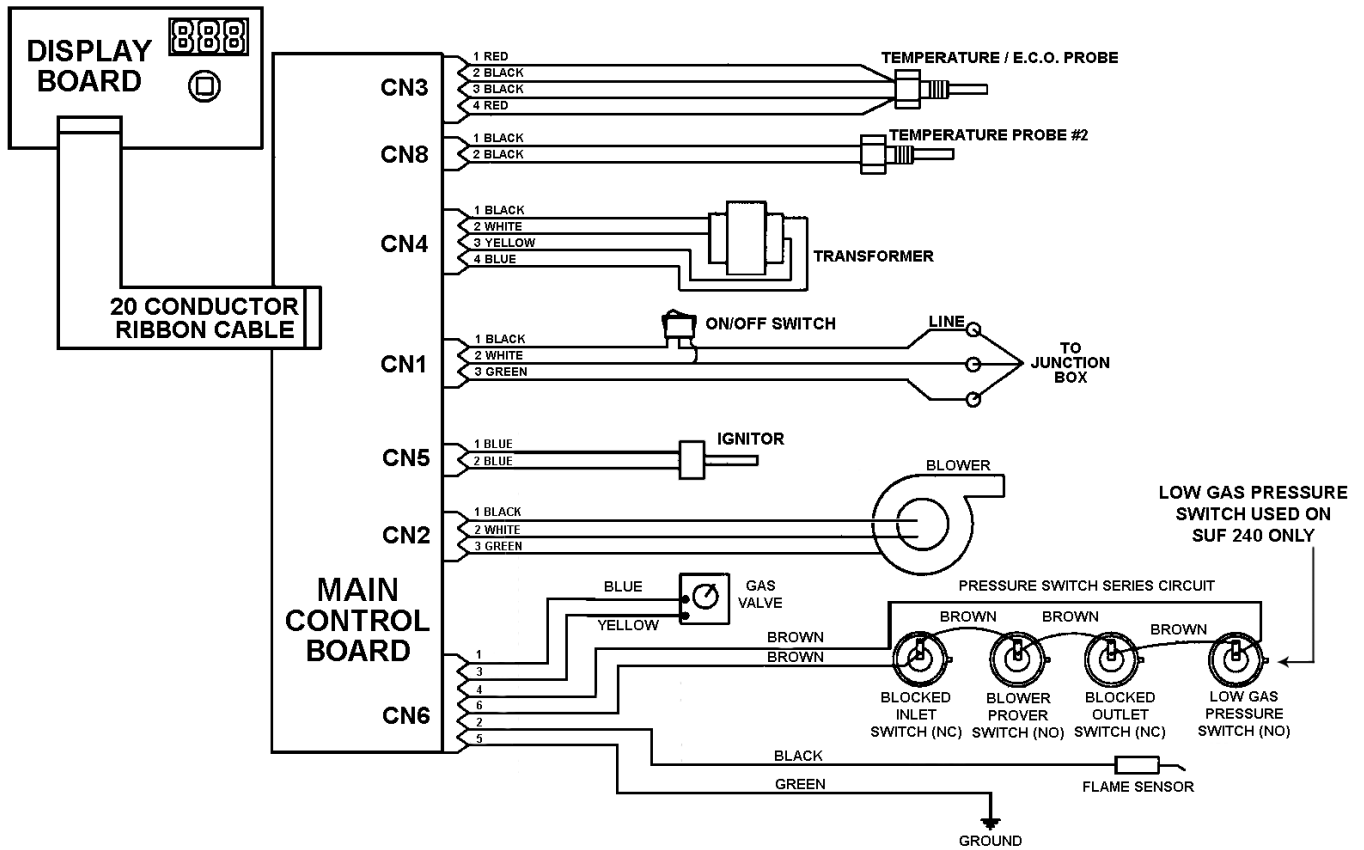

## SERVICE AIDS

1. This type product is **polarity sensitive**. Be certain that your electrical supply wire neutral has no voltage.
2. This unit will produce condensation — quite heavily at times. The outlet drain hose **must be allowed to drain**. Exhaust Vent piping must also drain condensate. Code 11 error would imply that these must be checked.
3. If the unit is located in a cold climate, take steps to ensure that exhaust vapors are not pulled into the air intake. Terminate both pipes on direct vent installations in the same area, but **maximize the distance** between them.
4. Do **not** combine vent these units.
5. Pushing the reset button at random times may alter setting of the control. Note the sequence of operation comments on when to push this button.
6. If you make a setting change, **cycle the heater** with this new setting to lock it into memory.
7. The first items to check on a service call
  - a. Correct venting installation
  - b. Drainage of condensate from hose and exhaust vent pipe
8. SUF models are certified to 6.800 ft. above sea level with the standard orifice — air and gas.
9. The temperature display board indicates **average** tank water temperature. If one tank sensor is “open”, the indicator will display the active sensor temperature. (Because the top tank sensor also contains the high limit-24V-sensor, disconnecting this from the control board results in an error code (04).)
10. Temperature and pressure relief valve operation. **Weeping** usually indicates thermal expansion. **Large volume** discharge usually indicates excessively hot water operation.
11. SUF models are well within decimal level limits, but if you desire to lower the installation level approximately 6 decibels a muffler (Part No. 195334) may be installed in the exhaust vent.

## SUF MUFFLER

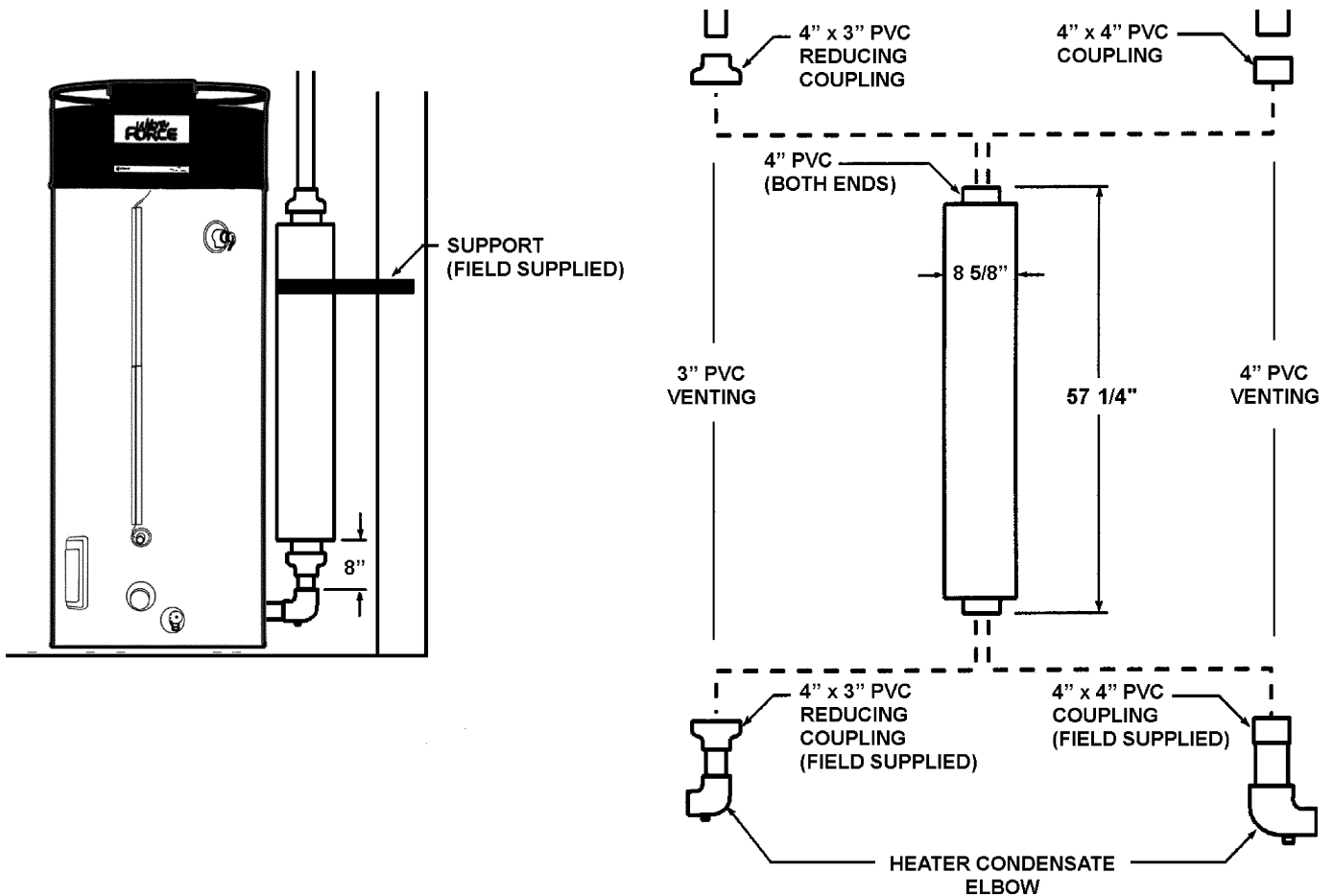

### NOTES :

1. Install muffler in vertical position only.
2. Muffler must be a **minimum** of 8" from top of condensate elbow.
3. The muffler inlet and outlet are 4" PVC. If venting with a 4" PVC, a 4" x 4" PVC coupling (field supplied) must be cemented to each end of the muffler. If venting with 3" PVC, a 4" x 3" PVC reducing coupling (field supplied) must be cemented to each end of muffler (see illustration above.)
4. Cement muffler into a location using ASTM D-2564 grade cement.
5. Secure muffler to suitable structure.
6. Operate heater through 1 heat cycle to ensure there are no exhaust leaks and there is no obstruction of exhaust flow.

## QUESTIONS AND ANSWERS

**Q. How much electrical power is required for a SUF water heater?**

A. The SUF models draw approximately 5.0 Amps Max.

**Q. When should SUF's be delimed?**

A. Many variables affect the lime build up process including:

- *Water temperature* — the amount of lime accumulation during the same period of time will be nearly 2 times great if water is stored at 140 degrees F than at 120 degrees F. A 180° setting may accumulate seven times more lime — in a period of time — than at 140° setting.
- *Volume of water* — the more gallons flowing through the SUF, the more rapid the accumulation.
- *Hardness* — the harder the water the quicker lime build up occurs. 1 to 3.5 grains per gallons is “soft”, 3.5 to 7 grains per gallon is “moderate”, 7 to 10.5 grains per gallons is “hard” and 10.5+ grains per gallon is “very hard”. (An aspirin is about 5 grains. One grain is equal to 17.1 parts per million.)

A. Deliming should be done when a slight rumbling or popping sound is detected when the main burner is on. Check for accumulation through the clean-out opening.

**Q. What effect will lime build-up have on the SUF water heater?**

A. One eighth inch of scale buildup on the heat exchanger may reduce efficiency as much as 22%; a ¼ inch buildup, as much as 38%.

Less efficient heat transfer means more heat exchanger expansion/contraction stress and premature leakage.

Because the heat transfer to the water is made through a (relatively) small diameter, coil type exchanger tube, expansion and contraction as well as the shape of the exchanger greatly reduces buildup on the heat transfer surface. The bottom of the tank should be checked for dislodged accumulation.

**Q. Anode rods (4) provide additional protection against corrosion. When should these be replaced?**

A. When large gouges or pits appear in the anodes, replace them.

**Q. How often should the anodes be inspected?**

A. Approximately every six months.

**ERROR CODES**

CODE	INDICATION
00	This is <b>normal operation</b> , 00 is displayed each time the heater is powered up.
01	Indicates the pressure switch circuit was not open during the prediagnostic system check when the proper state of the Draft Prover Switches are verified. The Blower Prover Switch is normally open, the circuit should therefore be open during the prediagnostic system check at the beginning of each cycle. Check Blower Proving Switch for continuity with the blower off, there should be no continuity, check pressure switch wiring.
02	Indicates the heater <b>failed to light after 3 trials</b> . Check ignitor, gas pressure.
04	Indicates <b>the ECO is open</b> . Check water temperature in tank, ECO will open at 202° F and can be reset below 160° F.
05	Indicates a <b>Temperature Probe is open</b> . Check both probes for proper resistance and continuity.
11	Indicates the <b>Pressure Switch Circuit did not close</b> after blower was energized. Check normally open Blower Prover Switch operation, check normally closed Blocked Outlet, Inlet, and Low Gas pressure (SUF 240 only) to ensure they remain closed. Check for blocked vent pipe (s) or if equivalent feet venting limits have been exceeded.
15	Indicates <b>temperature</b> sensed by probe(s) is <b>out of bounds</b> , reading is <b>less than 30° F</b> . Check resistance of temp probes, check water temperature in tank.
22	Indicates <b>Ignition Relay failure</b> . Should be off and it is on. Try resetting, turn power off and on, if code remains, replace board.
25	Indicates <b>temperature</b> sensed by probe(s) is <b>out of bounds</b> . Reading is more than 220° F. Check resistance of temp probes, check water temperature.
<b>CODE #S ABOVE 199</b>	<b>Internal software or hardware errors</b> , electrical line noise can cause erratic operation and these error codes. Try adding a <b>“line filter”</b> (available from electrical suppliers) to the 120 VAC power supply. If these errors codes persist or the control cannot be reset, replace the control board.

All these errors cause a “soft” lockout with the exception of 04 - ECO, which is a “hard” lockout. Soft lockouts will reset automatically after 60 minutes or if the reset button is pushed at any time. The ECO lockout, error code 04 will have to be manually reset by pushing the rest button after water in the tank has cooled below 160° F.



## SERVICE CHECKLIST

This is not intended to be an all-inclusive list of the problem that the Service Agent may encounter. Any item checked "no" on this list should be thoroughly investigated and corrective action taken, if required.

SERVICE AGENT: \_\_\_\_\_ INSTALLATION DATE: \_\_\_\_\_  
 MODEL NUMBER: \_\_\_\_\_ SERVICE DATE: \_\_\_\_\_  
 SERIAL NUMBER: \_\_\_\_\_ LOCATION ADDRESS: \_\_\_\_\_  
 PHONE (     ) \_\_\_\_\_

**GAS TYPE — CHECK ONE**

NATURAL \_\_\_\_\_  
 PROPANE \_\_\_\_\_

PROPER GAS VALUE VERIFIED                      YES \_\_\_\_\_ NO \_\_\_\_\_

**I. CHECK CLEARANCE (CIRCLE ANSWER)**

- A. Are exterior clearances adequate? \_\_\_\_\_ yes no  
 B. Are interior clearances adequate? \_\_\_\_\_ yes no  
 Comments: \_\_\_\_\_

**II. CHECK MAKEUP AIR REQUIREMENTS**

- A. Is the quality of make-up air adequate? \_\_\_\_\_ yes no  
 Comments: \_\_\_\_\_  
 B. Is the quantity of make-up air adequate? \_\_\_\_\_ yes no  
 Comments: \_\_\_\_\_

**III. GAS PRESSURE (FILL IN BLANK) — ALL UNITS ON.**

- A. Supply gas pressure \_\_\_\_\_ inches of W.C. (flowing)  
 B. Manifold gas pressure (main burner) \_\_\_\_\_ inches of W.C. (flowing)  
 Comments: \_\_\_\_\_

**IV. VENTING (CHECK)**

- A. Acceptable equivalent footage \_\_\_\_\_ yes no  
 B. Proper material \_\_\_\_\_ yes no  
 C. Proper exterior installation \_\_\_\_\_ yes no  
 D. Condensate will drain \_\_\_\_\_ yes no  
 Comments: \_\_\_\_\_

**V. WATER PIPING**

- Is the system properly sized? \_\_\_\_\_ yes no  
 Is the system properly installed? \_\_\_\_\_ yes no  
 Are there any water leaks? \_\_\_\_\_ yes no  
 Does the installation have a recirculating system? \_\_\_\_\_ yes no  
 If so, is it operational? \_\_\_\_\_ yes no

**VI. SAFETY**

- A. Air  
 If exhaust is blocked will unit lockout? \_\_\_\_\_ yes no  
 If air intake is blocked will unit lockout? \_\_\_\_\_ yes no  
 B. Water Temperature  
 - Is the thermostat adjusted to the lowest acceptable temperature? \_\_\_\_\_ yes no  
 - Does the installation have a mixing valve? \_\_\_\_\_ yes no  
 - If so, is it operational? \_\_\_\_\_ yes no  
 - What is the outlet temperature of the mixing valve? \_\_\_\_\_ yes no

**NOTE:** To minimize the risk of scalding, the manufacturer recommends storing water at 120° F.

- Is a properly rated temperature and pressure relief valve installed? \_\_\_\_\_ yes no  
 Is there a properly installed expansion tank? \_\_\_\_\_ yes no  
 Should there be? \_\_\_\_\_ yes no  
 C. Electrical  
 Is the 120 VAC electrical powers supply properly wired? (including polarity) \_\_\_\_\_ yes no  
 Are all the SUF control covers in place? \_\_\_\_\_ yes no  
 Is the 120 VAC electrical power supply properly fused? \_\_\_\_\_ yes no  
 D. Flammables  
 Are flammable materials located in the area of the water heater? or air intake? \_\_\_\_\_ yes no  
 Are flammable vapors located in the area of the water heater? or air intake? \_\_\_\_\_ yes no  
 E. Gas  
 If the gas supply is reduced or turned off will the unit turn off? \_\_\_\_\_ yes no  
 Comments: \_\_\_\_\_

[This service checklist may be photo copied to assist with SUF service calls.]



**ULTRA FORCE SUF MODELS REPLACEMENT PARTS**

ITEM	DESCRIPTION	SUF 100 150	SUF 100 199	SUF 100 240	SUF 100 150-LP	SUF 100 199-LP
1	Anode	43817-53	43817-53	43817-53	43817-53	43817-53
2	*Barb,Hose	181863	181863	181863	181863	181863
3	Blower	193354	193354	193203	193354	193354
4	Board,Display Panel	192622-0	192622-0	192622-0	192622-0	192622-0
5	Burner Assembly	194114-1	194114	194114-2	194114-5	194114-4
6	Clamp, 3	192696	192696	192696	192696	1926964
7	Clamp, Hose	192806	192806	192806	192806	192806
8	Clamp,Hose,Nylon	191794-1	191794-1	191794-1	191794-1	191794-1
9	Condensate Hose	191746-72	191746-72	191746-72	191746-72	191746-72
10	*Direct Vent Kit	193202	193202	193281	193202	193202
11	Elbow, 90 Degree	192473	192473	192473	192473	192473
12	Exhaust Terminal	192815	192815	192815	192815	192815
13	Flame Rod Assembly	192478	192478	192478	192478	192478
14	Flange, Inlet	192641-1	192641-1	192886-1	192886-1	192886-1
15	Gasket, C.O	99038	99038	99038	99038	99038
16	Igniter Assembly	192638	192638	192638	192638	192638
17	*Instruction Manual	195723	195723	195723	195723	195723
18	Intake Terminal	182167	182167	181762	182167	182167
19	Orifice, Gas	192477-1	192477	192477-2	192477-5	192477-4
20	Panel,Front	195721	195721	195721	195721	195721
21	Plate, C.O	99037	99037	99037	99037	99037
22	*Screen, Exhaust	181662	181662	181662	181662	181662
23	Press. Switch, Low Gas	-----	-----	191149-1	-----	-----
24	Tube, Air	192469-10	192469-10	192469-10	192469-10	192469-10
25	Valve, Drain	26273-4	26273-4	26273-4	26273-4	26273-4
26	Valve, Gas	192797	192797	192454	192454-1	192454-1
27	Valve, Relief	192467	192467	192467	192467	192467
28	Gasket, Burner	192331	192331	192331	192331	192331
29	Metal Cage Assy	195731	195731	195731	195731	195731

Shaded parts are recommended stock items for emergency replacement. Consider gas used in your area only.  
\*Not illustrated.

S U F S E R V I C E H A N D B O O K  
P A R T S L I S T

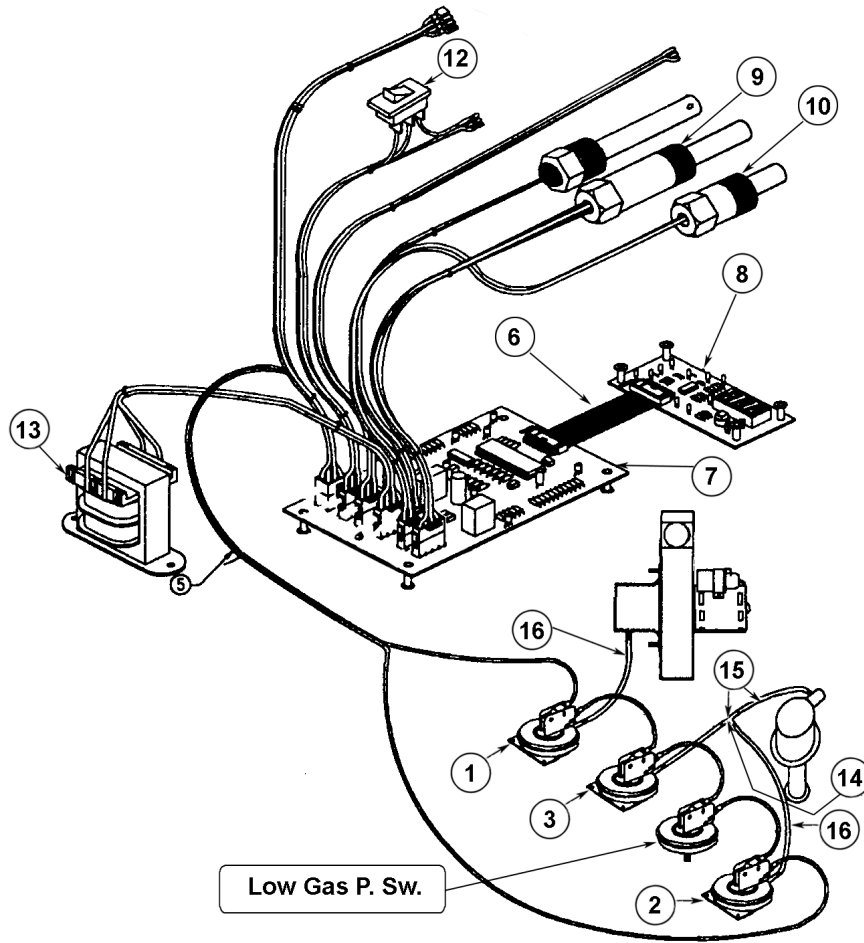

ULTRA FORCE SUF CONTROLS PARTS LIST

ITEM	DESCRIPTION	SUF 100 150	SUF 100 199	SUF 100 240	SUF 100 150-LP	SUF 100 199-LP
1	Blocked Inlet Switch	193355	193363	193361	193355	193356
2	Blocked Outlet Proving Switch	193362	193364	193357	193357	193357
3	Blower Proving Switch	193295	193295	193295	193295	193295
6	Cable to Control	192623	192623	192623	192623	192623
7	Control Board	193822	193822	193822	193822	193822
8	Display Board	192622	192622	192622	192622	192622
9	E.C.O./Upper Probe	196597	196597	196597	196597	196597
10	Lower Temperature Probe	196598	196598	196598	196598	196598
12	Switch-On/Off	193243	193243	193243	193243	193243
13	Transformer	192608-1	192608-1	192608-1	192608-1	192608-1
14	Tubing, Connector	192152	192152	192152	192152	192152
15	Tubing, Pressure	192024-3	192024-3	192024-3	192024-3	192024-3
16	Tubing, Pressure	192024-8	192024-8	192024-8	192024-8	192024-8

Shaded parts are recommended stock items for emergency replacement. Consider gas used in your area only.

**NOTES:**

Prepared by the State Water Heaters Training Department.  
For additional technical information call 800-365-0577.

